

***RCS***

**HVAC Zone Control Systems**

**Model ZCV4**  
**Four Zone HVAC Control Unit**  
With RS485 Communications

Rev G

**INSTALLATION AND OPERATION MANUAL**

DCN: 141-01066-04

7/13/06

**\*\*\* IMPORTANT NOTICE \*\*\***

**DO NOT USE THIS PRODUCT FOR BUILDING FREEZE PROTECTION! YOU ARE ADVISED TO  
INSTALL A MECHANICAL FREEZE PROTECTION DEVICE ON YOUR SYSTEM FOR THIS PURPOSE.**

The ZCV4 HVAC Zone Control Unit provides four independent heating and cooling zones when connected to a single HVAC system. Each zone can be controlled by a “Wall Display Unit” or, if preferred, simply by a wall mounted temperature sensor. Zonal temperature control is accomplished by controlling motorized zone dampers to open or close the flow of conditioned air into each zone. The ZCV4 also has an RS485 communications port for connecting to control networks and controllers, such as the RCS CommStar products.

The ZCV4 uses RCS Wall Display Units (WDU), which are similar looking to typical “thermostats”, but are digital communicating multi-function user interfaces with graphical displays, user controls and a local temperature sensor.

***Please note that you cannot use standard thermostats with the ZCV4 HVAC Control Unit, only RCS TS16 or TS40 Wall Display Units can be connected to it.***

Installation of the ZCV4 control unit is easy. The control unit connects to the HVAC system’s thermostat connections just like a traditional thermostat does. The Wall Display Units connect to the ZCV4 with a 4 wire cable. Each Zone damper is a two wire connection (or three wire for optional heavy duty dampers).

The ZCV4 will take care of providing the heating or cooling as needed to satisfy each zone’s requirements.

## **Fully Independent Zone Control**

Operation of the system is just like having two independent thermostats. Set each zone to the heating/cooling mode desired and adjust the zone temperature as needed. The ZCV4 will automatically delivery the heating/cooling needed to satisfy each zone’s requirement. Mixed modes are allowable among the zones, that is, one zone may be set to heating while another may be set to cooling. The system is fully automatic and has auto changeover capability. Heating calls are give priority over cooling calls. The Zone Control Unit monitors the setpoint and modes of all zones and determines what heating calls will be satisfied first and when all heating calls are satisfied, the system mode will switch to cooling to satisfy all cooling calls as needed.

## **HVAC System Compatibility**

**Standard or Heat Pump HVAC System Types.** The ZCV4 can work with either standard Gas/Electric or Heat Pump HVAC systems. System type is selectable on the control board.

For Standard HVAC systems, the ZVC4 can be set to work with either Gas heating or Electric heating.

For Heat Pump HVAC systems, the ZCV4 changeover valve operation can be set for either changeover with cooling or changeover with heating.

## **Multi-Stage HVAC Compatibility.**

For Standard HVAC systems, the HVAC outputs support 2 stages of heating and 2 stages of cooling.

For Heat Pump HVAC systems, the HVAC outputs support 3 stages of heating (2 compressor/1 heatstrip) and 2 stages of cooling.

## **Fresh Air Ventilation**

The ZCV4 includes the “Smart Vent” feature which provides for automatic fresh air ventilation. The Smart Vent operation is controlled from the TS40 Wall Display Unit and provides several modes of manual, timed and automation vent operation. A vent damper relay output is provided for control of a fresh air intake damper.

## Zone Damper Control

The ZCV4 features “Fail Safe” zone damper operation by using **normally open** dampers. In the event that zonal control is lost, all dampers are open so that heating or cooling to all zones is possible until zone control can be restored. During normal operation, when a zone calls for cooling, **all other zones not calling will be closed**. At the end of the call, all dampers will return to open. This “all zones normally open mode” also allows for system wide ventilation. Refer to the Damper section for specific damper selection information.

## Remote Communications.

The ZCV4 control units have a RS485 serial communications port for network communications. Remote systems can request zone data such as zone temperature, mode and/or operating status. They can also set the operation of zones by sending new setpoints and heating/cooling modes. The communications protocol (refer to RCS protocol document 150-00225) supports an extensive command set for a robust control and monitor capability.

Up to 254 ZCV4s can be networked together in a HVAC control network along with other RCS communicating thermostats. RCS Automation Control Units, such as the CommStar Models CS30/308/48, can support up to 32 HVAC zones.

## Outside Temperature Operation

The ZCV4 can use and display outside temperature information from a sensor attached to the ZCV4 control unit or from outside temperature data received from the network. In either case, the outside temperature will be displayed on all zone WDU's.

**Outside Temp Sensor Attached to the ZCV4.** When a outside temp sensor is attached to the ZCV4, it is “enrolled” as an active sensor when the unit powers up and initializes. Changes in outside temperature are sent to the wall display units for local display and also reported on the network.

**Reporting Outside Temperature on the Network.** When an Outside Temp Sensor is attached to the ZCV4 Outside Temp Sensor Input, the outside temperature will be reported on the network in response to the Request Status message R=1. The outside temperature shows up as “OA=xx” in the status message data string.

**Displaying Network Outside Temp Data.** If a local outside temp sensor is **not** connected to the ZCV4, outside temperature data can be received from the network and the ZCV4 will treat it just like a local sensor is installed. **If a local outside temp sensor has been installed on the ZCV4 it will inhibit network outside temp data from being accepted.** This is true even if a outside sensor was enrolled and then disconnected but has not been un-enrolled by resetting the ZCV4.

Note that **network provided** outside temp data will NOT be reported in Request Status R=1 message response (no “OA=” data will appear).

## Wall Display Units

RCS Wall Display Units that are **RCSLink2** products, such as Model TS16 and TS40 can be used with ZCV4 controllers.

**Note: At least one TS40 Wall Display Unit is required on the ZCV4 HVAC Zone Control Unit for system configuration and access to the Installer Settings menus.**

**Reminder: You cannot use standard thermostats with the ZCV4 HVAC Zone Control Unit.**

# HVAC OPERATION AND SETUP

---

## General Heating and Cooling Operation

In the **HEATING** mode, the heating system will be turned on at one degree below the setpoint and will turn off at the setpoint. This turn on and turn off offset is referred to as the heating setpoint “delta T” and is adjustable in the Installer Settings menu of the TS40 WDU. It is default set to the one degree operation.

In the **COOLING** mode, the cooling system will be turned on at one degree above the setpoint and will turn off at the setpoint. Similarly, the cooling setpoint delta T is adjustable in the Installer Settings menu.

In the **AUTO** mode, the system will switch between heating and cooling as determined by the heating and cooling setpoints and the current temperature. Once in a heating or cooling mode of operation, the normal one degree setpoint control is maintained.

**Setpoint Push.** Heating and cooling setpoints are forced to maintain a separation between them, with a default setting of 4 degrees. If the heating or cooling setpoint is changed to be within the setpoint delta, the system will automatically “push” the other setpoint to maintain the setpoint delta separation. The H/C setpoint delta is also adjustable in the Installer Settings menu of the TS40 WDU.

## Standard HVAC System Types

Gas or electric heating systems are considered “Standard” HVAC systems. These systems consist of an indoor furnace/blower assembly and an outdoor AC condensing unit (for those systems with air conditioning installed). These systems in general are referred to as central forced air HVAC systems.

You must configure the ZCV4 control unit for your HVAC system type for correct system operation.

### Setup

#### Standard System Type Selection.

To set the Control Unit for standard Gas/Electric HVAC system operation, set the dipswitch DIPSW1 to STD position (OFF). This is the default setting.

#### Fan Type Selection.

Gas systems do not require a fan output for heating operation. Set dipswitch DIPSW1-S2 to GAS (OFF) system fan type operation.

Electric (and hydronic) heating systems do require a fan output with the call for heating. Set dipswitch DIPSW1-S2 to ELECT (ON) for ELECTRIC system fan type operation.

***Be sure to check your HVAC system’s requirements.***

## Heat Pump HVAC System Types

Heat Pump HVAC systems are combined heating and cooling systems. The system consists of an indoor “air handler” (a blower fan and coil assembly) and an outdoor unit. Heat pumps change from heating mode to cooling mode by switching the refrigerant flow using a “changeover” or “reversing valve”. In both heating and cooling operation the compressor and fan outputs are on and the state of the changeover output determines if heating or cooling is being provided. Heat pumps can have one or two stages of compressor operation plus an optional third stage of electric heat strips.

The third stage of heating will be turned on when the current temperature falls 5 deg below the current setpoint and will turn off at 3 degrees below the setpoint.

## Setup

### Heat Pump System Type Selection

To set the Control Unit for Heat Pump HVAC operation, set the dipswitch DIPSW1-S1 to HP (ON).

### Changeover Type Selection

Most heat pump systems are designed to work normally in the heating mode and require a change over output for cooling output. Set the System configuration dipswitch DIPSW1 as follows for your system type.

Changeover with Cooling: Set DIPSW1-S2 to CO-C (OFF) This is the default setting.

Changeover with Heating: Set DIPSW1-S2 to CO-H (ON) position.

**Note: during Heat Pump operation the changeover relay, once engaged, will stay on until the Minimum Off Time (MOT) delay expires before dropping out.** If another call commences before the MOT timeout, it will avoid unnecessary cycling of the changeover valve.

Check your HVAC system requirements for correct settings.

### Minimum Run Time (MRT)

The ZCV4 control unit has a Minimum Run Time after the start of any heat or cool call. This 6 minute minimum run time assures even heating and cooling cycles. Minimum Run Time will keep the system on even if you change the setpoint to a temperature that would satisfy the call, until it expires. Changing the Mode to OFF will cancel the MRT and the system will turn off immediately. MRT can be adjusted in the Installer Settings Menu of the TS40 WDU.

**Note: MRT status is shown in the TS40 WDU system status indicator.**

### Minimum Off Time (MOT)

The ZCV4 control unit has a Minimum Off Time after any heat or cool call. This 6 minutes delay prevents rapid heating/cooling cycles and also provides "short cycle protection" for compressor calls. This delay may be noticeable when you change a zone setpoint and it does not respond immediately due to another call have been recently completed and the MOT delay timer is preventing the restart of the system. The MOT delay time can be adjusted in the Installer Settings Menu of the TS40 WDU. There is a minimum of 5 minutes delay to assure compressor protection.

**Note: MOT status is shown in the TS40 WDU system status indicator.**

# NETWORK OPERATION

---

The ZCV series controllers have RS-485 serial communications that allows remote commands generated by other systems to be received by the ZCV. These remote commands can change the individual zone setpoint, temperature and modes or may request current status of a zone temperature, setpoint and mode. Remote commands received by the ZCV to change a zone setpoint or mode are sent to the zone WDU to update its display. Whenever new commands are received, the WDU will switch its display to show the updated information for three seconds and then return to the current temp display.

RS-485 connections are a twisted pair multi-drop network that can have up to 255 devices connected to one pair of wires. With use of a RCS Star Wiring Hub, wiring can also be “star” or “homerun” from each connected device to the host system, such as RCS CommStar network control units.

## Network Addressing

The RS485 address is set from the Wall Display Unit. Network address 0 is reserved for the Host control unit and address 255 is reserved for global commands.

Each zone in the ZCV control unit is treated like a separate thermostat and has its own RS485 address. When you set the address for the control unit, you are setting the **base address for Zone 1**. Each zone is sequentially addressed from this number. Note that zone addresses are assigned to all zones on the zone controller, even if they are not used.

For example: a 4 zone control unit set to address 1, each zone address is as follows:

Zone 1 = network address 1  
Zone 2 = network address 2  
Zone 3 = network address 3  
Zone 4 = network address 4

If the next device in the network is a ZCV4, it would need an address of 5 and the zones would be addressed as follows:

Zone1 = network address 5  
Zone 2= network address 6

WDU's can set any address from 1 to 254.

## Communications Parameters

The ZCV4 serial communications setup is 9600 baud, 8 data bits, no parity, 1 stop bit and no flow control.

The RS485 network connects to the screw terminal connector. The D+ and D- connections are required. The ground connection is optional, but can improve long distance communications and may be needed when the host and ZCV4 units are powered from different power sources.

## Communications Protocol

The ZCV series Zone Controllers uses the RCS serial communications protocol for HVAC control devices. This is an ASCII message protocol. Refer to the RCS RS-232/485 communications protocol document, PN: 150-00225, for detailed information on serial commands to communicate with the ZCV4 HVAC control units.

Note that not all commands in the protocol document are applicable to or supported by the ZCV4. The protocol document has an appendix that identifies specific ZCV4 commands.

## LOCATION AND MOUNTING

Install the Control Unit in a protected, convenient, INDOOR location near the HVAC system or in a service accessible area such as an equipment closet or garage.

Mount the Control Unit in a vertical position on a wall or sturdy structural member. The unit may be mounted on the HVAC system but care should be taken to avoid the hot burner section or high vibration areas.

## WIRING

### Wiring To The Wall Display Units

**Wire specification:** 4 conductor, 18Ga thermostat wire, 22Ga twisted pair or Cat 3/5 wire (preferred)

The Control Unit connects to each zone's Wall Display Unit or Sensor by four wires. In retrofit applications, the existing thermostat wiring may be used, however, for best results and in new construction, a Category 5 twisted pair cable is recommended.

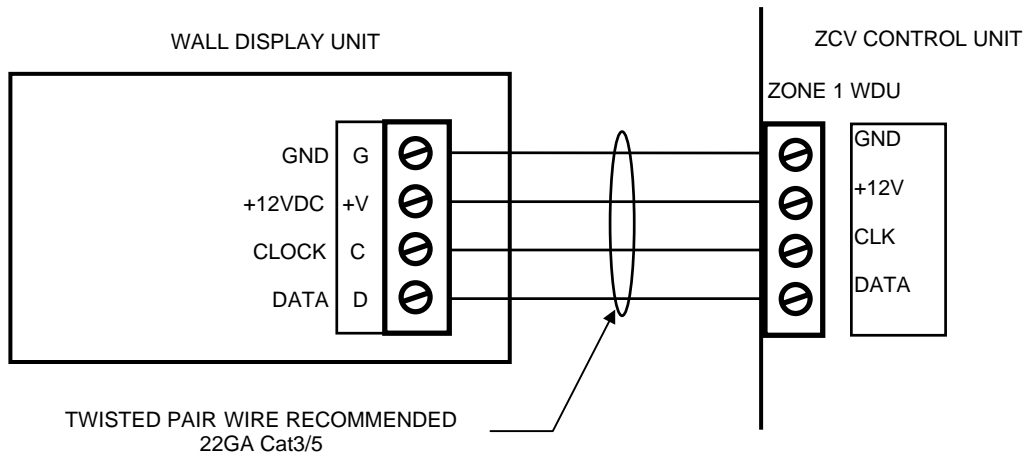

**CAUTION!** Do not mis-wire the Wall Display Units – damage may result. Check the wiring before applying power to the Control Unit.

### Wiring To The Outside Temp Sensor (if installed)

**Wire specification:** 2 conductor, 22Ga twisted pair or Cat 3/5 wire (preferred)

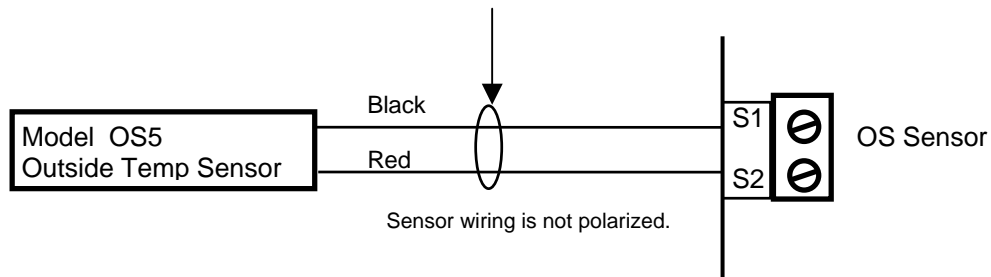

# Zone Damper Wiring

## Wire specification:

- RD Series dampers require 2 conductor cable
- RDM Series dampers require 3 conductor cable
- Recommended wire: 18/20GA thermostat wire.

The ZCV4 HVAC Control Unit has zone damper output relays plus a fresh air vent damper output. These SPDT relays are rated at 1 Amp, 24VAC. Zone outputs support either two wire (normally open, power close/spring return) or three wire dampers (power open, power close).

### Two Wire Damper Wiring

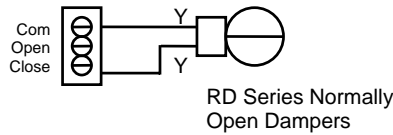

### Three Wire Damper Wiring

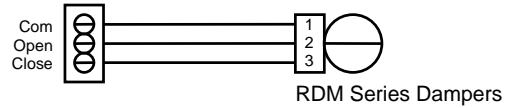

## ZONE DAMPERS

**ZCV4 Zone Controllers require Normally Open dampers.**

Without any heating or cooling calls, all zone dampers are open. When a zone calls for heat/cooling, the other zones that are not calling will have their dampers powered to the closed position.

This provides two important functions. First, if there is a zone output failure, the zone is still capable of getting heating or cooling. Second, it allows for ALL zone ventilation during periods of no heating or cooling (continuous fan mode).

### RCS Round Motorized Dampers

**RD Series round motorized dampers.** These standard dampers feature an extra rigid barrel with a self sealing blade that provides a 99% seal. Sizes 6 to 14 inches. They are 24VAC, 2 wire, 2 position, power close/spring return, normally open dampers. Current draw is 0.5 amps each. Rated for continuous power in the closed position. Part number: xxRDNO, where xx is damper diameter.

**RDM Series round motorized dampers.** These heavy duty dampers have the same extra ridge barrels of the RD series, coupled with a commercial heavy duty 3 wire damper motor. Sizes 6 to 20 inches. They are powered open and powered close. Current draw is 0.1 amps max each. Rated for continuous power in the open and closed positions. Part number: xxRDMNO-FP

***The xxRDMNO-FP dampers are the preferred damper for use with the ZCV control units.***

## POWER

The ZCV4 HVAC Control Unit requires 24VAC power. Power is provided by an external transformer (not supplied). This transformer must be rated for the max damper load. Calculate the transformer VA rating required by adding up the current draw for the number of dampers attached for the worst case load when only one zone calls and all others close.

(Total dampers -1) x (amp draw for each damper) x 24 = transformer VA rating.

Ex: ZCV4 4 zone controller: (4-1) x (.5A) x 24 = 36VA, so use a 40VA transformer.

## Network Wiring

### Connecting to RS485 Communications Ports

The RS485 communications port is a 2 wire (D+ and D -) plus ground, half-duplex network connection. Wiring options are direct to the com port, daisy chained to other thermostats, or wired to a RCS RS485 hub to allow star or homerun wiring.

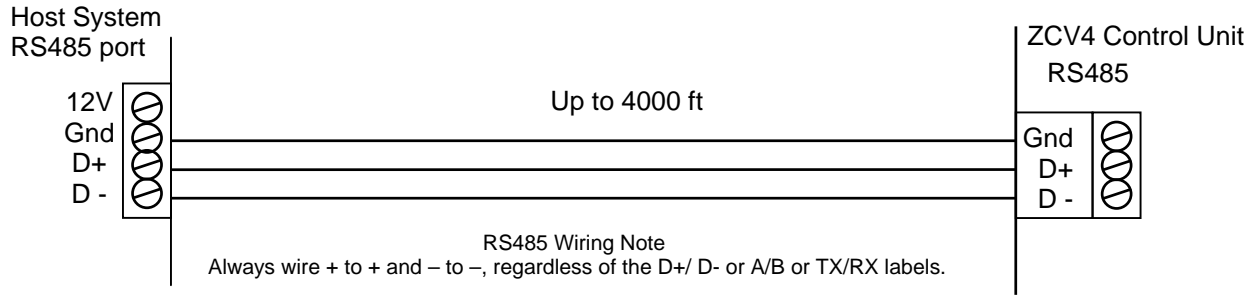

### RS485 Wiring Methods

- The ZCV4 control unit can be wired by three methods:
1. Direct connection to RS485 com ports (as above)
  2. Multi-drop (daisy chained) to other thermostats/devices
  3. Homerun wired to a Star Hub.

### Multi-drop Wiring

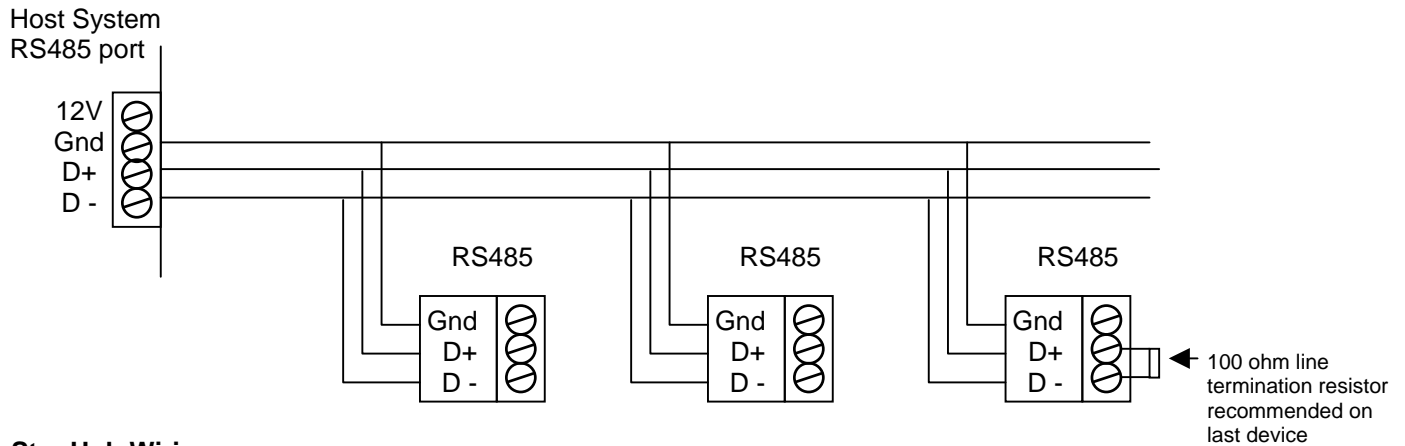

### Star Hub Wiring

CommStar Model CS308 or 8AH485  
8 channel Star RS485 Hub

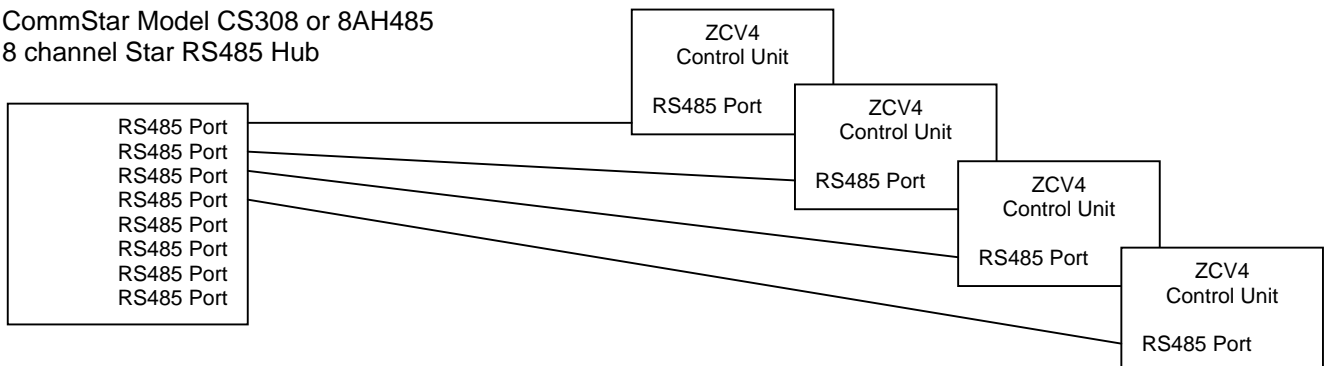

## Connecting to RS232 Communications Ports

Using **Model 485DB9TB** RS232 to RS485 Converter.

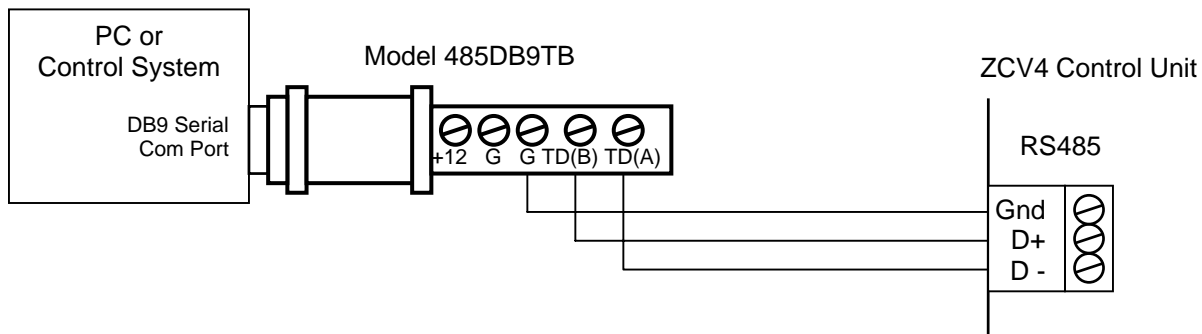

Using **Model 485PB** RS232 to RS485 Converter

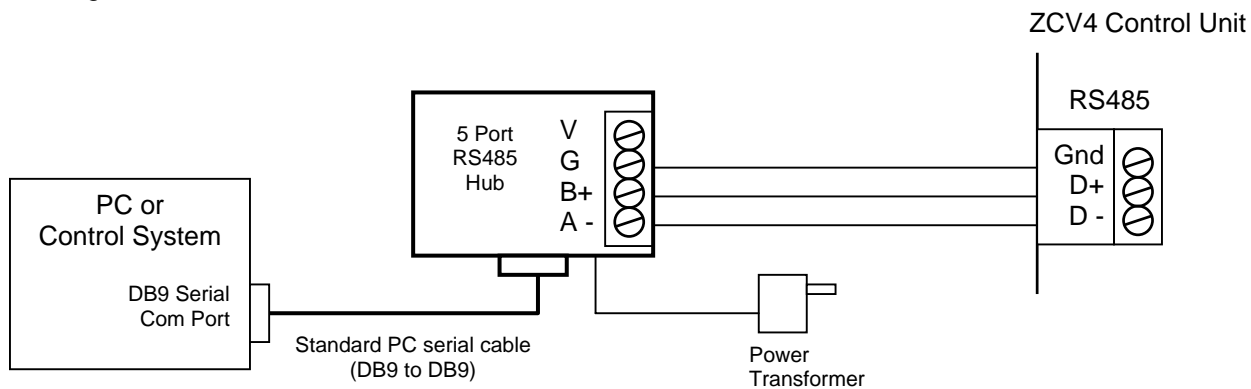

# HVAC SYSTEM CONNECTION

Electrically, the ZCV4 Control Unit looks like a standard thermostat to your HVAC system. All connections to the HVAC systems are made at the normal thermostat connection on the HVAC unit.

Refer to the following HVAC wiring information for the type of HVAC system, Standard or Heat Pump, that the ZCV4 control unit is being connected to. Refer to your HVAC system's documentation for specific information on its thermostat connections.

## Standard Gas/Electric HVAC System Wiring

ZCV CONTROL UNIT

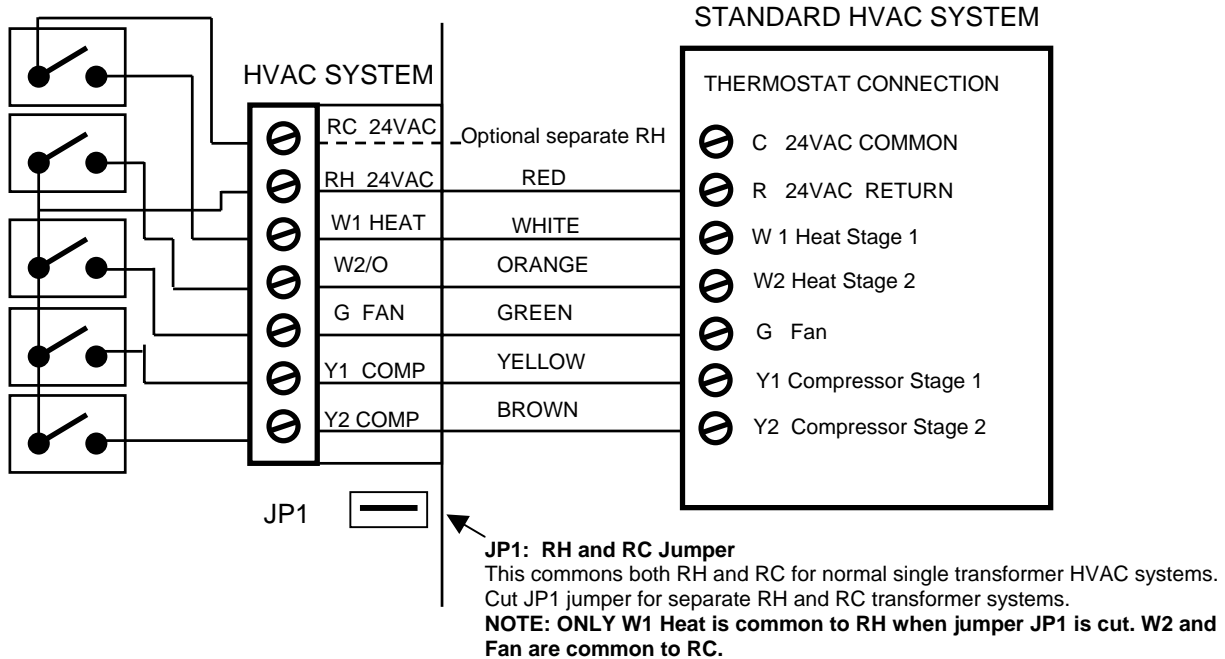

## Heat Pump HVAC System Wiring

ZCV CONTROL UNIT

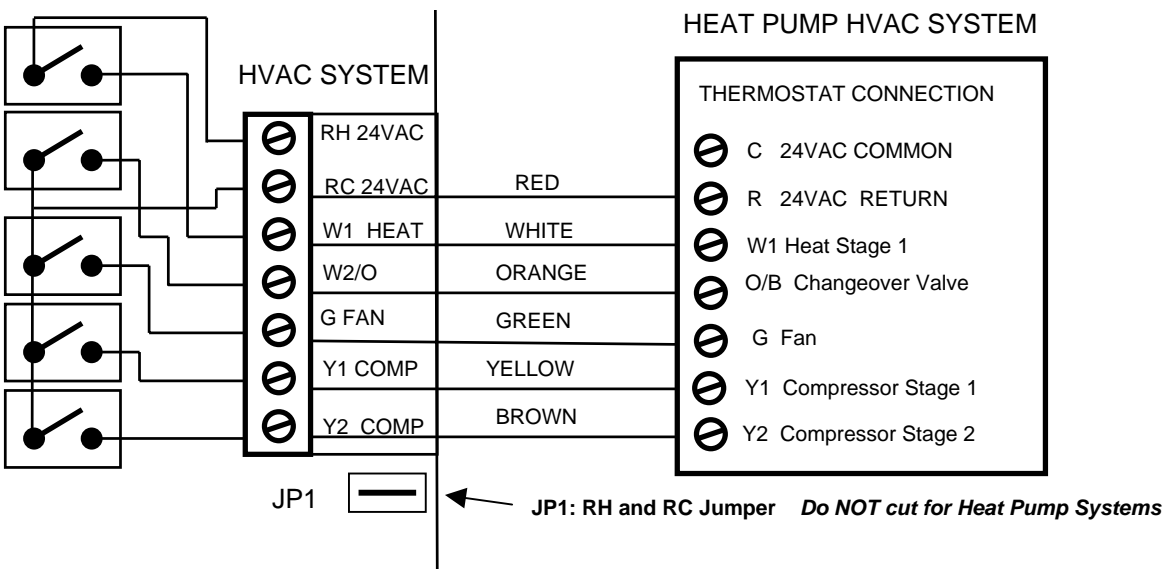

# SYSTEM CHECKOUT

It is strongly recommended that you hook-up and run a simple bench test before installing this controller. Not only will this save you time in system checkout but will also familiarize you with the ZCV4 operation.

## QUICK TEST

NOTE: Before power up, set the dipswitch, SW1, to ALL OFF.

1. Connect a Wall Display Unit to ZONE 1 input on the Control Unit with a short 4 wire cable.
2. Connect the 24VAC transformer to the Control Unit.
3. Plug the transformer into a 110v outlet and apply power to the Control Unit.
4. Verify Power Status LED is **flashing**.
5. Verify the WDU display comes on and shows the current temperature.
  - a. If no display or a "CF" display is shown on the WDU, **double check your wiring**.
  - b. Do not proceed until the current temperature is displayed on the WDU and communications between it and the Control Unit is OK. Any problems will result in a "CF" (Communications Failure) display on the WDU.
6. Press the Fan button on the WDU. The Control Unit Fan LED and relay should turn on. Also all damper LED's should turn on except Zone 1.
7. Press the Fan button again. The Fan LED and all relays should turn off.
8. Press the Mode button until the WDU is showing "H" for Heat Mode.
9. Press the Setpoint Up button until the setpoint is above the current temperature. The Heat LED and relay should come on.
10. Press the Mode button until the WDU is showing "O" for OFF. The Heat LED and relay will turn OFF.
11. Press the Mode button until the WDU is showing "C" for Cool Mode.
12. Press the Setpoint Down button until the setpoint is below the current temperature. The Cool and Fan LEDs and relays should turn on.
13. Press the mode button until the WDU is showing "O" for OFF Mode.
14. All LEDs and relays should turn off.
15. When you have successfully completed all these tests, you have verified that the Control Unit and the WDU are working and communicating correctly.

## Communications Test with a PC

1. With the Control Unit and WDU connected as above, proceed with connecting the ZCV's RS485 connection to a PC serial port (COM1) using a RS232 to RS485 converter (Model 485DBTB or eqv).

**Note: If not using a RCS RS485 Converter, be sure that the converter supports Send Data Control.**

2. Set ZCV4 base address to 1
3. Start the Hyperterm terminal emulator program in Windows/Accessories/Communications/Hyper Terminal.
4. Set Hyperterm communications parameters for COM1 to 9600 baud, no parity, 8 data bits, 1 stop bit and NO flow control.
5. **Set CAPS lock on (Commands are case sensitive).**
6. Send the Request for Status command R=1. Type "A=1 R=1" followed by the carriage return (cr).
7. ZCV should respond with the R=1 status response showing temp, setpoint, mode and fan for zone 1 (A=00 O=1 Z=1 T=(current temp) SP=70 M=0 F=0)
8. Set zone 1 Mode to Heat. Type "A=1 M=H (or 1) cr".
9. Zone 1 WDU should change to show the new mode is "H".
10. Set zone 1 setpoint to 78 degrees. Type "A=1 SP=78 cr"
11. Zone 1 WDU should change to show a setpoint update of "78".
12. If the WDU responds properly to these commands, proceed with installation.

It is recommended that you install the ZCV and then rerun these quick tests BEFORE you connect the Control Unit to the HVAC system. You will be confident that the ZCV is working correctly before you attempt to interface the HVAC system.

# HVAC SYSTEM QUICK TEST

In the event that you have difficulty with the ZCV controlling the HVAC system, you can perform the following quick test to confirm that the HVAC system is working correctly.

The ZCV Control Unit connects to the HVAC system at the **normal thermostat connections** on the HVAC unit. Standard thermostat control of the HVAC systems consist of contact closures in the thermostat. You can verify that your HVAC system is working correctly by duplicating these contact closures by shorting across the proper terminals on the HVAC systems thermostat connection. Refer to the following HVAC system example.

## HVAC SYSTEM EXAMPLE

This is a simplified diagram of an HVAC System and Thermostat. The Thermostat operates like switches to control the HVAC Fan, Heat, and Cool functions.

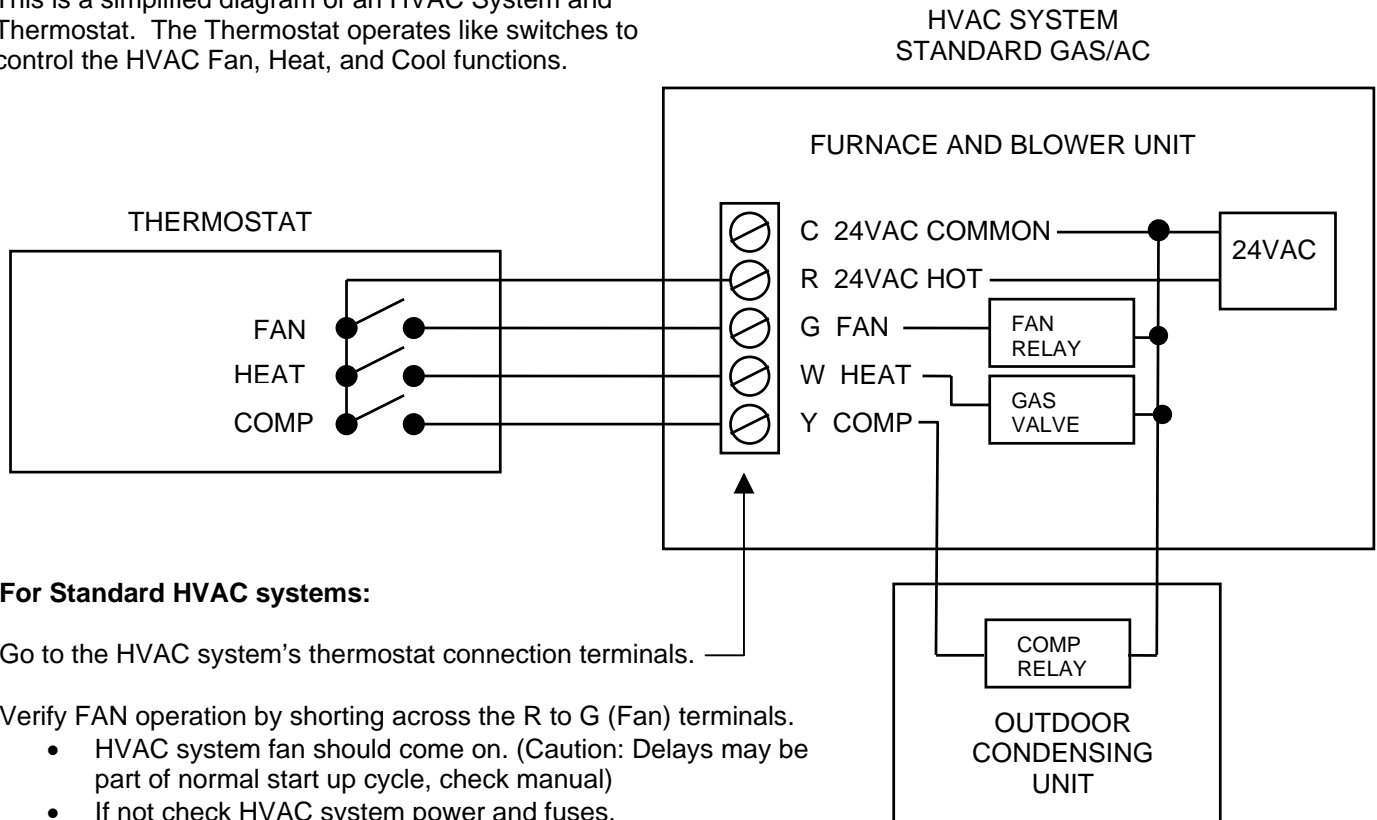

### For Standard HVAC systems:

Go to the HVAC system's thermostat connection terminals.

Verify FAN operation by shorting across the R to G (Fan) terminals.

- HVAC system fan should come on. (Caution: Delays may be part of normal start up cycle, check manual)
- If not check HVAC system power and fuses.
- If power is OK, HVAC system is NOT working correctly.

Verify HEAT operation by shorting across R to W (Heat) terminals (A Fan call is not necessary for gas furnaces).

- Heating operation should start. (Caution: Delays may be part of normal start up cycle, check manual)
- If not, check wiring, check 24VAC power is on R terminal. (measured across R to C).
- If power is OK, HVAC system is NOT working correctly.

Verify COOL operation by shorting across R to Y (Compressor) and R to G (Fan) terminals.

- Cooling operation should start. (Caution: Short Cycle Protection 5 minute delays are normal between calls and may delay start)
- If not, check wiring, check 24VAC power is on R terminal (measured across R to C)
- If power is OK, HVAC system is NOT working correctly.

### For Heat Pump systems:

Follow the above test to check the FAN operation. If FAN works OK, then power is verified also.

Short across R to Y and R to G. You should get either Heat (normal) or Cool operation depending on the whether your system is changeover with cool (normal) or heat.

Short across R to Y, R to G and R to O/B(Changeover terminal) to get opposite heat or cool operation from step 2. **If any of these checks fail, the HVAC system is not working correctly.**

# Model ZCV4

## 4 ZONE HVAC CONTROL UNIT

### Wiring Diagram

Rev G Control Board

