

RCS

# Model TZ40 Communicating Thermostat

with ZWave Communications

## Installation and Operation Manual

### Rev P HVAC Control Unit

DCN: 141-00885  
Revision 16

Date: 1/26/06

**This manual applies to these TZ40 Revisions or later**

Model	Rev	Part Number	Firmware Version
TZ40 Thermostat	P	001-00885	
TS40 Wall Display Unit	D	001-01060-26	3.07.4
HFR HVAC Control Unit	P	001-01430-01	3.05.2

**\*\*\* IMPORTANT NOTICE \*\*\***

DO NOT USE THIS PRODUCT FOR BUILDING FREEZE PROTECTION! YOU ARE ADVISED TO INSTALL A MECHANICAL FREEZE PROTECTION DEVICE ON YOUR SYSTEM FOR THIS PURPOSE.

**Residential Control Systems Inc.**

The TZ40 Thermostat provides typical thermostat functions as well as the capability to send and receive information via **ZWave** communications. This communications capability allows the thermostat's setpoint, mode and fan operation to be changed or monitored remotely.

The thermostat consists of three parts, a **Wall Display Unit (WDU)**, a HVAC **Control Unit** and the **ZWB ZWave Adapter**. The Wall Display Unit looks like a traditional thermostat and is the wall mounted user interface for the TZ40. It provides display, control pushbuttons, and the temperature sensor. The WDU connects to the Control Unit by a 4 wire cable. The Control Unit connects to the HVAC system in place of a standard thermostat and provides thermostatic control of the system. The ZWB ZWave communications adapter connects to the control unit RS485 port and can be located in a convenient location up to several hundred feet from the HVAC system.

The Model TZ40 can be used with up to 3 remote temperature sensors such as the RS15.

### TZ40 Wall Display Unit

The TZ40 WDU is a Model TS40 and has a backlit LCD graphical display, control buttons, LEDs and a digital temperature sensor. The WDU can display multiple screens. In the default thermostat screen, it shows the current temperature, setpoint, mode and manual fan mode, time, outside temperature and other information.

Any changes in temperature, or control button operations, are transmitted to the Control Unit. Updates are received from the Control Unit and displayed by the WDU.

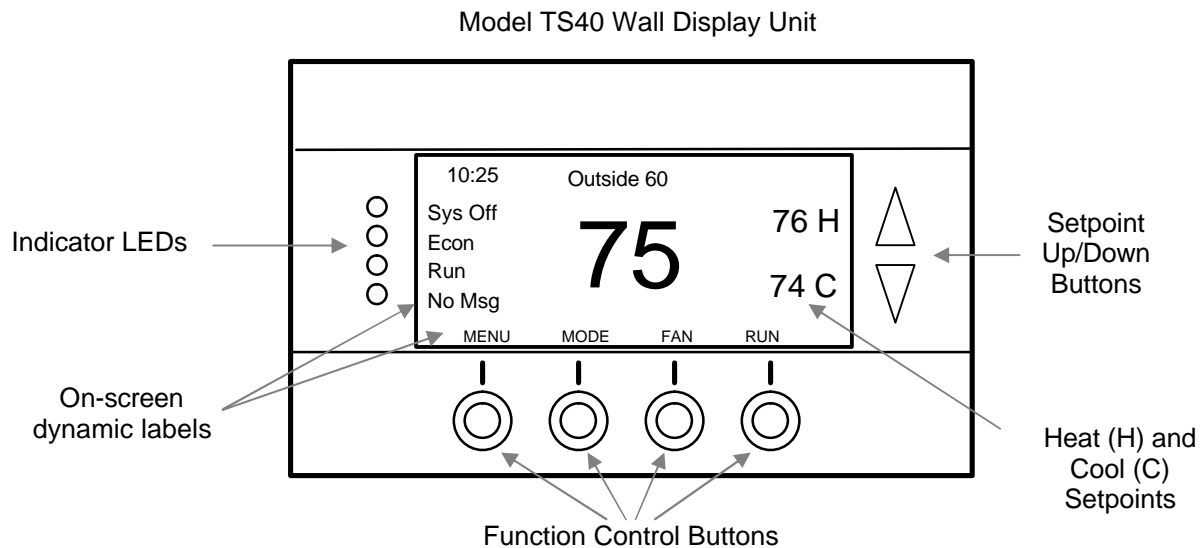

### TS40 Wall Display Unit Display

The TS40 display is a graphical LCD display capable of both text and graphics. The WDU has multiple display "screens". The main screen is the thermostat screen shown above. This screen has a "minimized" mode in which only the temperature is displayed. It reverts to this minimized mode after a timeout delay period.

Other standard screens are selected by the Menu button and include: Messages, Schedules, User Settings, and Thermostat Info. Others may be present and selectable from the menu button in special versions of the WDU.

The TZ40's LCD features a backlit display for low light and night visibility. It can be set to remain on constant or to turn out after a 20-45 second delay.

## Wall display Unit Control Buttons

All 6 buttons on the TS40 Wall Display Unit are “Soft Keys” meaning that they change functions when you change screens. The function of the buttons is defined by “on-screen labels” that are dynamic and change when you change screens. The following are definitions for the buttons for the main “Thermostat screen” and their primary mode of operation. Other screens and their button operations are defined in following sections.

## Wall Display Unit LEDs

The TS40 has four LED's that display various status information. The LEDs have dynamic “on-screen” labels that can change with the screen being displayed.

## Wall Display Unit “Screens”

One of the unique features of the TS40 WDU graphical display is the ability to have multiple display screens. In addition to a main thermostat control screen, menus and other control screens for special functions are provided. This makes an intuitive and easy to use “user interface”. It allows the many functions of the TZ40 to be easily navigated.

The TS40's main screen is the Thermostat Control Screen. From this screen you can access a menu screen that will list other control screens or setup screens.

### **Thermostat Control Screen**

This is the default main screen and the only screen needed for basic thermostat operation (temperature setting and heat/cool mode selection). All other screens will automatically timeout and return this screen after 120 seconds of no activity.

### **Minimized Thermostat Screen**

The main thermostat screen will go to a “minimized” screen after a 30 second timeout period. This presents a simple uncluttered display of the current room temperature and outside temperature (if an OT sensor is attached). This minimized screen can be disabled if desired.

Pressing any button when the minimized screen is displayed will causes the Thermostat Control screen to be restored and displayed.

### **Menu Selection Screen**

Pressing the Menu button on the Thermostat Control Screen will go to the Menu Selection screen. This screen presents a list of the other functions or setup screens that can be selected.

### **Messages Screen**

The TS40 is capable of receiving messages from the RS485 network. Messages received are displayed in the Messages Screen.

### **Schedules Screen**

This screen is used to setup and select setback schedules for the thermostat.

### **User Settings Screen**

This screen is a submenu of user settings for the initial setup of the thermostat. You can set the clock, minimized screen timeout, Fahrenheit or Centigrade selection, sensor calibration and display settings.

### **Thermostat Info Screen**

This is a quick reference list of the thermostat firmware versions and setup.

The following describes each Thermostat screen in detail.

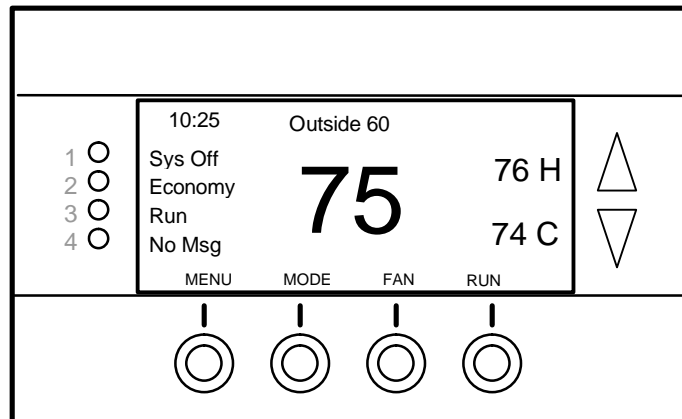

The thermostat control screen is the default display screen and is the screen that is normally displayed on the Wall Display Unit. It can be set to switch to a minimized screen of only room temperature after a few seconds of display. The User Settings menu allows selecting the screen timeout for a minimized screen. Pressing ANY button will bring this screen back from a minimized screen.

### Temperature Display

The WDU will normally display the current temperature from the internal digital temperature sensor or a remote sensor. The sensors have an accuracy of +/- 1°F(+/- .5°C). The WDU will display temperatures from -63°F to 191°F. **NOTE: If averaging remote sensors are attached, the display will show the average temperature of all attached averaging sensors.**

### Setpoint Display

The heating and cooling setpoints are displayed next to the Setpoint Up/Down buttons. In the HEAT mode, the Up/Down buttons change the heat setpoint. In the COOL mode, they change the cooling setpoint. When in AUTO mode, the buttons change the last call's heating or cooling setpoint. Note that the setpoints will "push" each other if they are adjusted to get within the minimum Heat/Cool separation (delta T) setting. This is normally 3 degrees.

### Clock Display

The current time is displayed in the upper left corner of the main screen. Set the clock from the User Settings Menu.

### Outside Temperature Display

The outside temperature is displayed in the top center of the main screen, if outside temperature information has been sent to the thermostat or a remote outside temperature sensor is connected to the WDU.

## Thermostat Control Screen Buttons

### Thermostat Control Screen - UP and DOWN Buttons

The **UP** and **DOWN** buttons adjust the setpoint temperature. Pressing the UP button will increment the setpoint value by one degree and conversely, pressing the Down button will decrement the setpoint one degree. Pressing and holding a button down will cause the setpoint to continuously change until the button is released.



The setpoints can be set from 40°F to 106°F ( 5°C to 37°C), **unless limited in the Installer Settings.**

**Setpoint Push:** Note that you cannot lower the cooling setpoint below the heating setpoint. The thermostat will “push” the heating setpoint lower if try to lower the cooling below the heating setpoint. It maintains a 3 degree separation between the heating and cooling setpoint. The same is true for raising the heating setpoint above the cooling setpoint. Again the thermostat will “push” the cooling setpoint up to maintain the 3 degree separation.

### Thermostat Control Screen - MENU Button

The Menu button changes the screen display to the MAIN MENU screen which show what other functions are available on the Thermostat. These are dynamic and can change with the version of the thermostat you have, but the standard ones include:

#### Main Thermostat Screen

##### → Menu Button

- Main Menu Screen
  - Messages
  - Schedules
  - User Settings
  - Thermostat Info

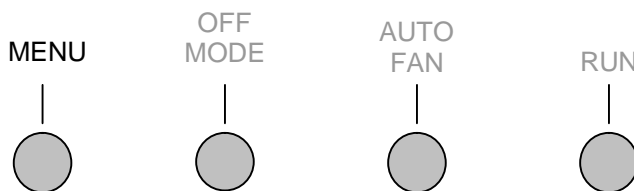

### Thermostat Control Screen - MODE Button

The **MODE** button controls the HVAC system mode. The current mode selected is displayed above the button. Pressing the **MODE** button will cause the mode and display to change to the next mode. The system mode cycles from **Off** to **Heat** to **Cool** to **Auto** and back to **Off** again with each press of the **MODE** button. When the HVAC system type is set to Heat Pump, the mode selection will include **EH** for Emergency Heat mode.

##### → Mode Button

- Off
- Heat
- Cool
- Auto
- EH

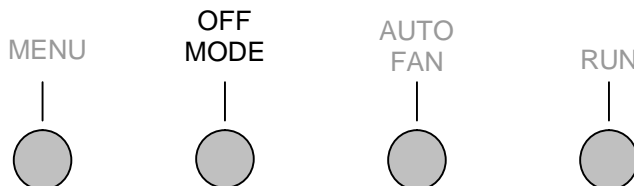

**Off Mode:** System is off. No heating or cooling will come on. If it was on, the system will turn off.

**Heat Mode:** Only heating will occur.

**Mode Button Continued**

**Cool Mode:** Only cooling will occur.

**Auto Mode:** Heating or cooling will come on according to the heating and cooling setpoints. The system will automatically switch between heating and cooling when the temperature exceeds the appropriate setpoints.

**EH Mode:** Only displayed when **Heat Pump** HVAC System type is selected. When there is a compressor failure with the heat pump system, setting the mode to EH will allow the supplemental heat to come on whenever there is a heat call to provide heating. It also disables the compressor outputs to prevent further damage to the system.

**Thermostat Control Screen - FAN Button**

The **FAN** button controls the HVAC system's **MANUAL** fan. The current manual fan mode is displayed above the button. Normally this button is in the Auto mode (the system fan is automatically controlled by HVAC system). Pressing the **FAN** button once will turn the manual fan operation ON. Pressing it again will turn the manual fan OFF and return to the AUTO mode (which means OFF unless turned on by the furnace or AC). Changes in the fan mode are sent to the Control Unit.

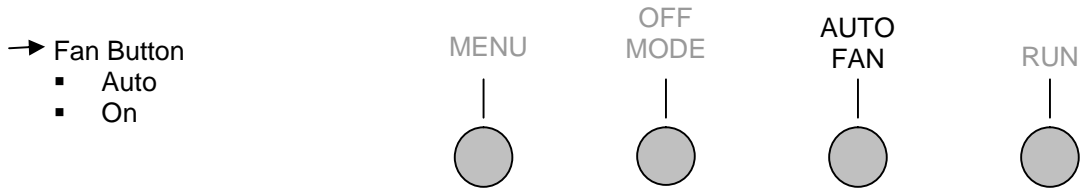

**Thermostat Control Screen - RUN/HOLD Button**

The **RUN/HOLD** button controls the automatic **SCHEDULE** operation. In the HOLD mode, the current temperature is maintained until changed by manual or remote network command. In the Run mode, the schedule loaded into the thermostat is activated and setpoints will change according to the schedule and the time and day of week. There is also an **AWAY** mode that you can select if you press and hold the button for 3 seconds. In the Away mode, preset Heating and Cooling setpoints are used.

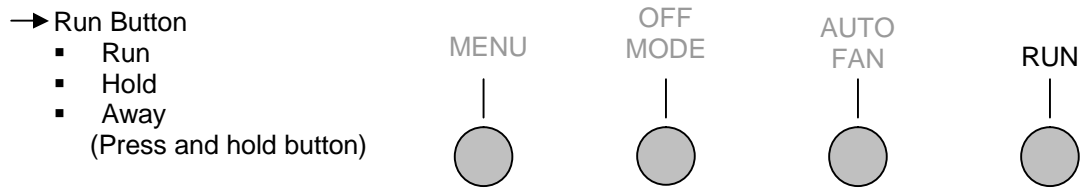

## Thermostat Control Screen - LED Displays

The Thermostat Control Screen has the following LED labels and descriptions, numbered from top to bottom, 1-4.

- **LED 1 Green: System Operation display.**
  - LED Off, "SYS OFF" displayed > HVAC system is OFF
  - LED Off, "SYS MOT" displayed > Minimum Off Time (MOT) delay on is active
  - LED On, "SYS ON" displayed > HVAC System is running
  - LED On, "SYS MRT" displayed > Minimum Run Time (MRT) delay off is active
  
- **LED 2 Green: System Economy Mode display**
  - LED OFF or On, "Econ" displayed > Economy or 1<sup>st</sup> stage heating or cooling only
  - LED On, "2<sup>nd</sup> Stg" displayed > Stage 2 heating or cooling is active
  - LED On, "3<sup>rd</sup> Stg" displayed > Stage 3 heating is active
  - LED On, "Vent" displayed > fresh air venting is active
  
- **LED 3 Green: Run/Hold display.** Shows state of Schedule Run/Hold Mode.
  - LED Off, "Run" displayed > Schedule is running
  - LED On, "Hold" displayed > Schedule is off, temperature setpoint hold in effect.
  
- **LED 4 RED: Alert LED.** Used for Messaging and other system alerts
  - LED Off, "No Msg" displayed > No text messages or Alerts present
  - LED On, Mail icon or Alert Text displayed > Message waiting or specific alert text

## "Communications Error" Display

If the WDU is not properly wired or if communications to the Control Unit is interrupted, the LCD display will flash "Comm Failure" at the top center of the Thermostat Control Screen (where outside temperature is normally displayed) . Momentary display of "Communications Failure" caused by loss of data, will clear automatically when data communication is restored. If the "Communications Failure" display stays on, check wiring or control unit for problems.

The Thermostat has a menu tree that can be accessed by pressing the “Menu” button on the Main Thermostat screen. Various configurations of the TS40 can have different screen contents. The first screen that will come up is the Main Menu screen. This is a list of the other menus or functions that can be accessed. Standard screens are listed below. Yours may vary with different configuration or revisions.

**Message Screen**

This is a text messaging subsystem that allows message of up to 80 characters to be sent to the thermostat. Message that are received are displayed when the message screen is selected.

**Schedules Screen**

This screen is used to set the programmable setback schedules of the thermostat.

**User Settings Screen**

This screen is used to set the Clock, Screen Timeout, F/C mode and Sensor Calibration and Backlight/Display settings.



**Thermostat Info Screen**

This screen shows the firmware versions of the WDU and Control Unit, HVAC system type and equipment options, and the network address of the thermostat.

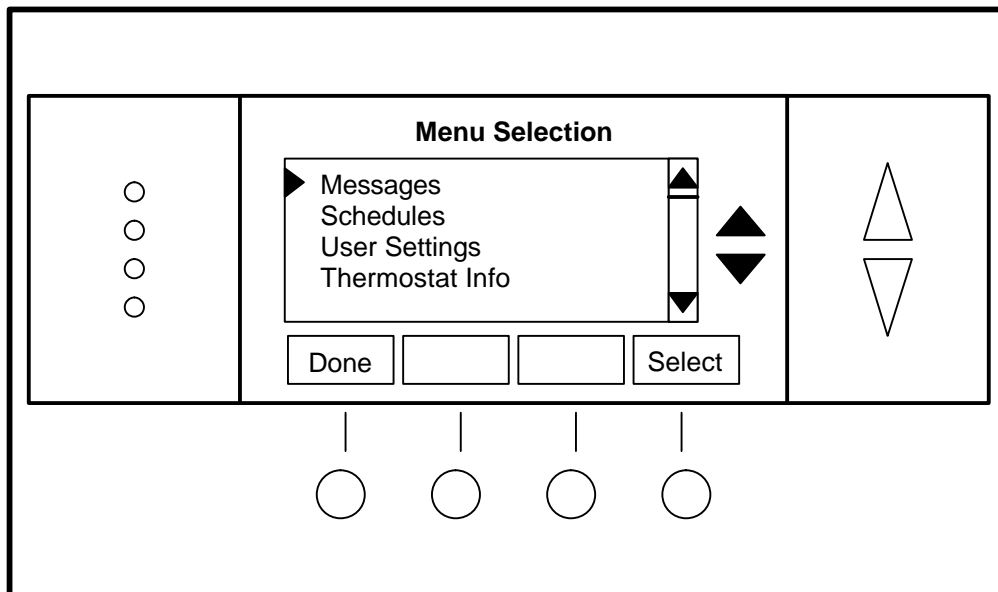
**Main Menu Screen**

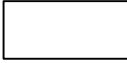

**Screen navigation buttons:**

-  Done Return to Thermostat Screen
-  Not used
-  Not used
-  Select Select menu item at pointer

 Move menu selection pointer up

 Move menu selection pointer down

The TS40 Message Screen allows you to retrieve text messages sent from the serial network to the thermostat. The message screen features navigation buttons to read new and old messages and delete them.

Up to 16 messages can be stored in the thermostat, if more than 16 messages are received, the oldest is erased to make room for the newest message. New messages will turn on and flash the Message LED and Mail Icon in the main thermostat screen.

Viewing messages makes them “old” and turns off the indicators. If you view some, but not all new messages, the new message notification LED and icon will stay on. Messages are entered as most recent message as number 1 message.

## Message Screen

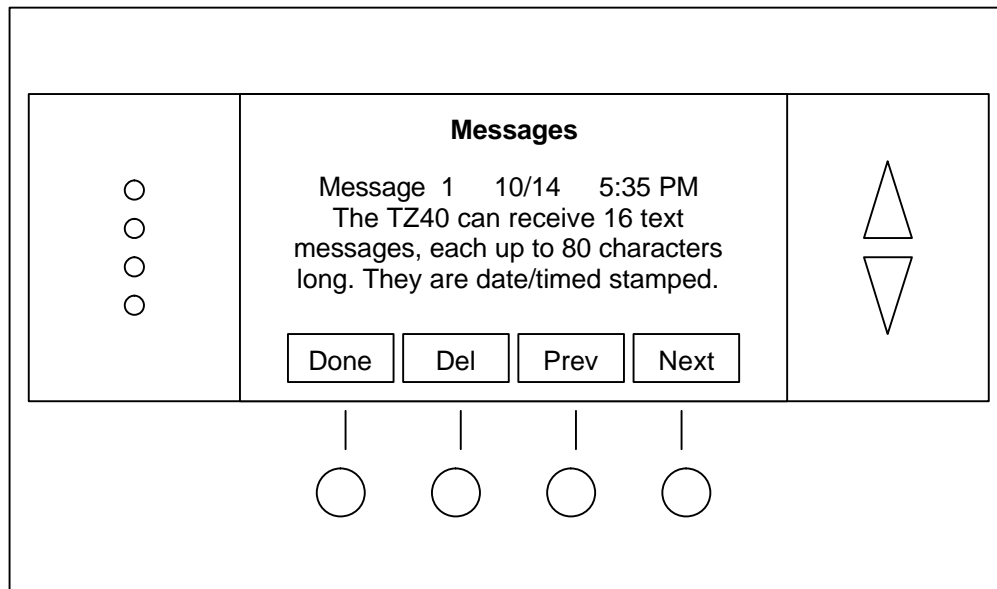

### Screen navigation buttons:

When you first select the Message Screen, the most recently received message will be displayed as Message 1. If other messages are stored in memory, they can be recalled and viewed or deleted by using the message memory navigation buttons.

<b>Done</b>	Return to Main Menu Screen
<b>Del</b>	Delete the Message being displayed
<b>Prev</b>	Display previous message. Scroll up in message stack
<b>Next</b>	Display next message. Scroll down in the message stack

The Schedules Screen allows you to review and set the setback schedule for the thermostat. The TZ40 has a 4 x 7 schedule. Four times a day can be selected for Heating and Cooling setpoints. Each day of the week can have a different schedule. Groups of days can be copied with the same schedule. When the TZ40 is set to "Run" mode, the schedule will be executed daily, with the setpoints being changed as per that days schedule stored in the thermostat. "Hold" mode stops schedule operation and holds the current setpoints until changed manually or by network commands.

The Schedules Screen gives you the option of setting a custom setback schedule or to load one of two preset schedules.



Menu Options

- **Heat and Cool:** You can change the individual day/hour and setpoints for the Heating and Cooling schedule by selecting this menu item.
- **Preset: Comfort:** This is a preset schedule with mild setbacks. Select this menu item to load the Comfort schedule into the thermostat.
- **Preset: EnergyMiser:** This is a preset schedule with deeper setbacks. Select this menu item to load the Energymiser schedule into the thermostat.

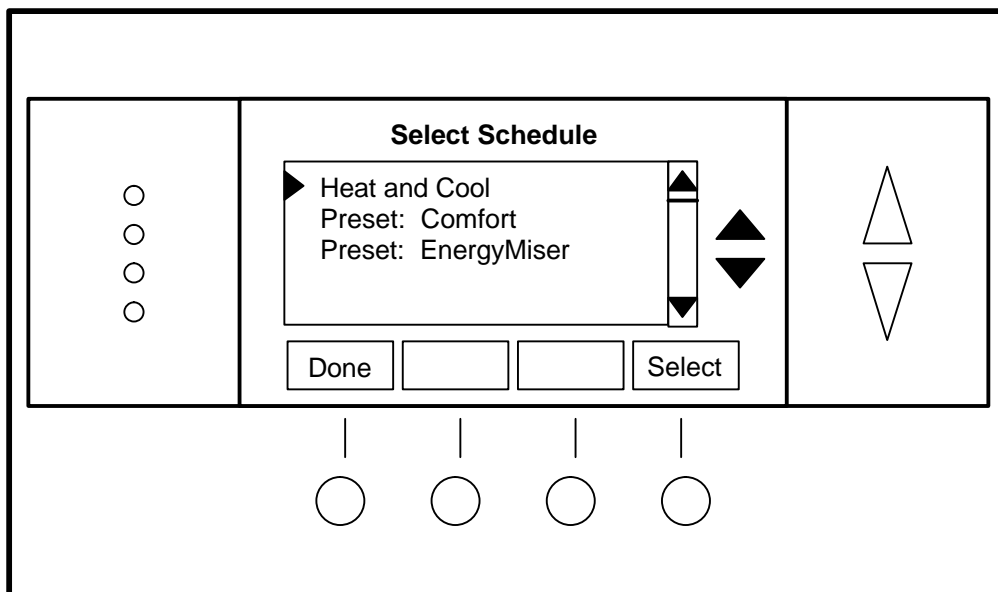
Schedules Screen

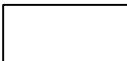

Screen navigation buttons:

<b>Done</b>	Return to Main Menu Screen		Move menu selection pointer up
			
			
<b>Select</b>	Select the schedule to view or modify		Move menu selection pointer down





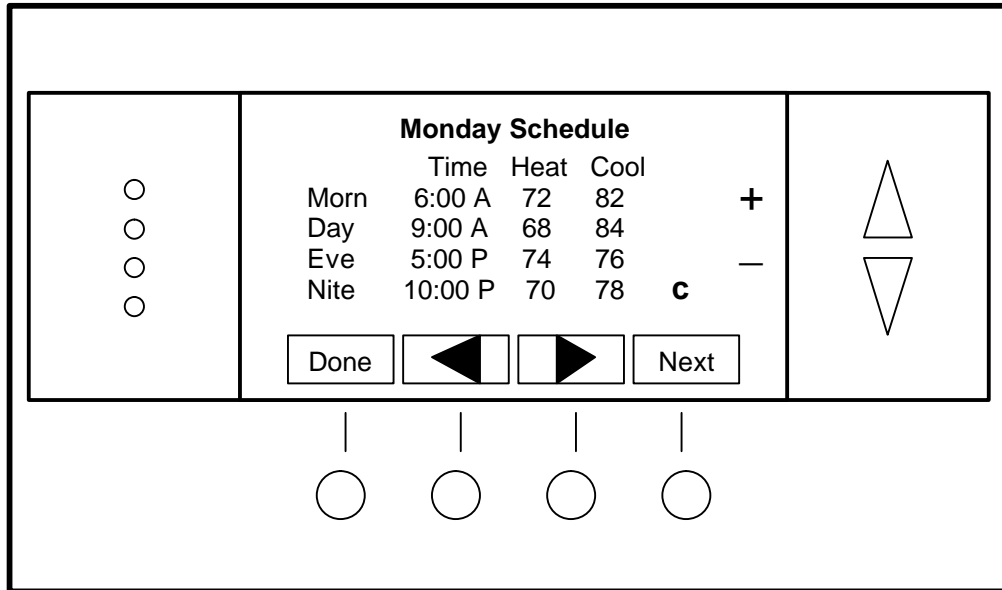

When you select the Heat and Cool Schedule menu item, the Schedule programming screen opens and the schedule for current day will be displayed. Use the scroll buttons to highlight the data to be modified. Once the data has been highlighted, use the +/- buttons to change the value of the data.

To copy a days schedule to another or group of days, move the cursor to “c” on the bottom right of the schedule screen. When you highlight “c”, the button below will become “Copy”. Press this button to change to the Copy Schedule Screen.

### Schedule Screen



### Screen navigation buttons:

-  Done      Return to Main Menu Screen
  -       Scroll Back
  -       Scroll Forward
  -  Next      Select the next Day schedule
  -  ↓
  -  Copy      OR if the copy “c” is selected, go to copy schedule screen.
-  + Increment time or temperature

 - Decrement time or temperature

The Copy Schedule screen is a sub screen of the Schedule screen. The Copy Schedule screen allows you to copy a day's schedule to another day or group of days.

First select the day to be copied in the Schedule screen. Scroll to the "c" at the bottom of the Schedule screen to highlight it. The "Next" button will change to the "Copy" button. Press the "Copy" button to open the Copy Schedule screen.

Scroll through the days and select the days the schedule is to be copied to by setting the "N" under each day to "Y" by using the Yes/No buttons.

After selecting all the days desired, press the "Copy" button.

Exit the Copy Schedule screen with the "Back" button.

### Copy Schedule Screen

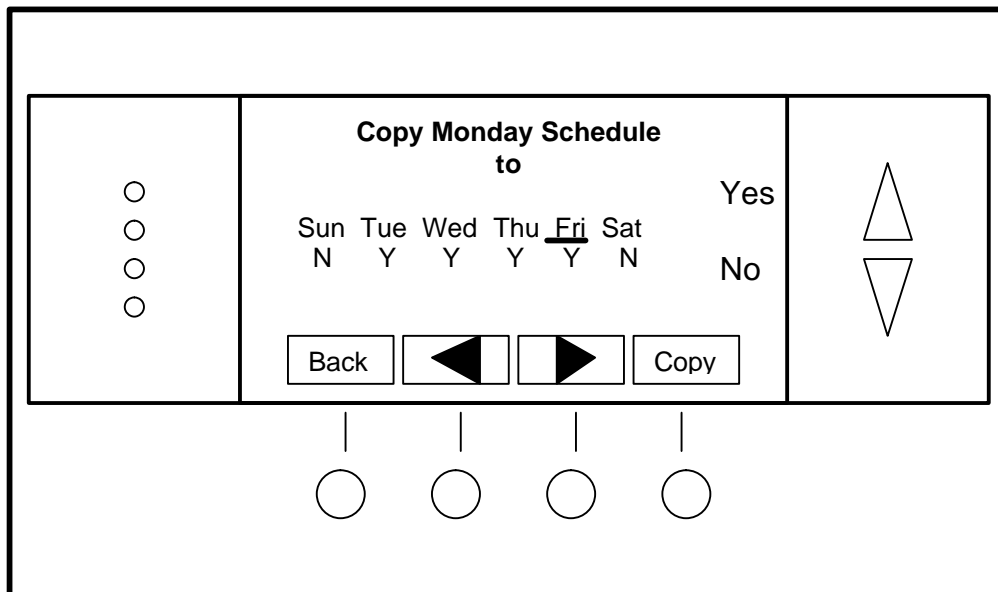

#### Screen navigation buttons:

- |             |  |                                   |
|-------------|--|-----------------------------------|
| <b>Back</b> | Return to Schedule Screen              |                                   |
| ◀           | Move back with selection bar           | △ Yes - Copy schedule to this day |
| ▶           | Move forward with selection bar        |                                   |
| <b>Copy</b> | Copy the schedule to the selected days | ▽ No - Do not copy to this day    |

The User Settings screen allows you to set or change various user options of the thermostat such as the clock, Minimized Screen timeout, Fahrenheit/Celsius mode, sensor calibrations, and backlight settings.

**Menu options:**

- **Set Clock**  
Select this menu item to go to the Clock setting screen.
- **Screen Timeout**  
Select the Screen Timeout time in seconds. Options are 0 or 15 to 127 (default set to 30 seconds). This is the time before any screen reverts to the **Minimized Screen** (temperature display only), after you stop pushing buttons. You can disable the Minimized Screen feature by setting this time to "0". If this is disabled, all screens revert to the main thermostat screen after 120 seconds.
- **F/C Select**  
Select which temperature display mode you desire, Fahrenheit (F) or Celsius (C) with +/- buttons.
- **Sensor Calibration**  
Select this menu item to go to the Sensor Calibration screen.
- **Backlite/Display**  
Select this menu item to go to the Backlite/Display settings screen. This menu allows you to set the backlight timeout period, On and OFF backlight brightness levels and adjust the display contrast.

**User Settings Screen**

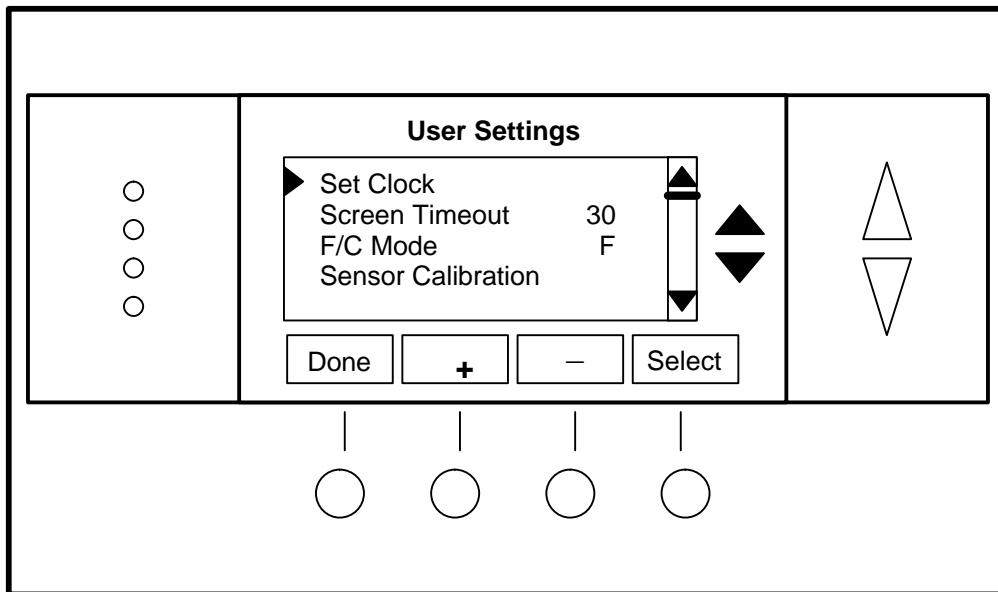

	Return to Main Menu		Move menu selection pointer up
	Increment value		
	Decrement value		
	Select the function to be set		Move menu selection pointer down



The Set Clock screen allows you to set the Thermostat internal clock.

To set the Time and Day, move the cursor with the navigation arrows until the data you want to change is highlighted.

Using the + and – arrows to increment or decrement the data to the desired setting.



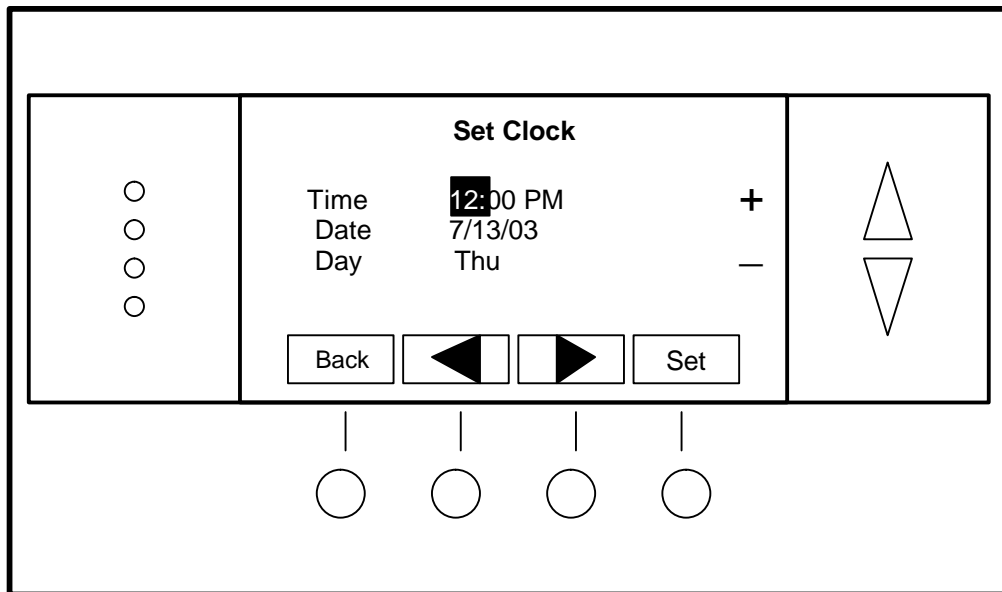

When finished, press the **SET** button to return to the Main Menu screen or wait for screen to timeout.

**NOTE: If the clock has been reset by an extended power outage, the Clock display on the thermostat screen will be blinking. Pressing the MENU button will take you directly to this screen to set the clock.**

### Set Clock Screen

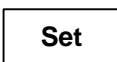

#### Screen navigation buttons:

	Cancel and return to User Settings Menu		+ Increment selected item
	Move back with selection box		- Decrement selected item
	Move forward with selection box		
	Set the time and return to User Settings Menu		

The Sensor Calibration screen allows you to change the temperature calibration for the internal and any external remote temperature sensors attached to the TZ40 WDU. You can change the temperature calibration by +/- 7 degrees.

When the Sensor Calibration screen is selected it will show the internal and all **detected** remote sensors. Each sensor found will show the current temperature (The (75) in the example screen below) and the current number of degrees of offset being applied (1 deg in the example). "n/a" means that the remote sensor is not attached. If the sensor's actual temp is (74) with 0 degrees of offset and you want it to be 75, then press + to add 1 deg and it will show (75).

To change the temperature calibration, use the scroll buttons to select the internal or a remote sensor. Once selected, use the + and - buttons to change the temperature calibration to the desired setting.

The value shown in the (xx) is the calibrated or offset temperature that you want the sensor to show.

You can update the info on this screen by pressing the right hand (blank) button.

When you close this screen, it may take a few seconds for the temperature to update to the new temperature on the main thermostat screen.

### Sensor Calibration Screen

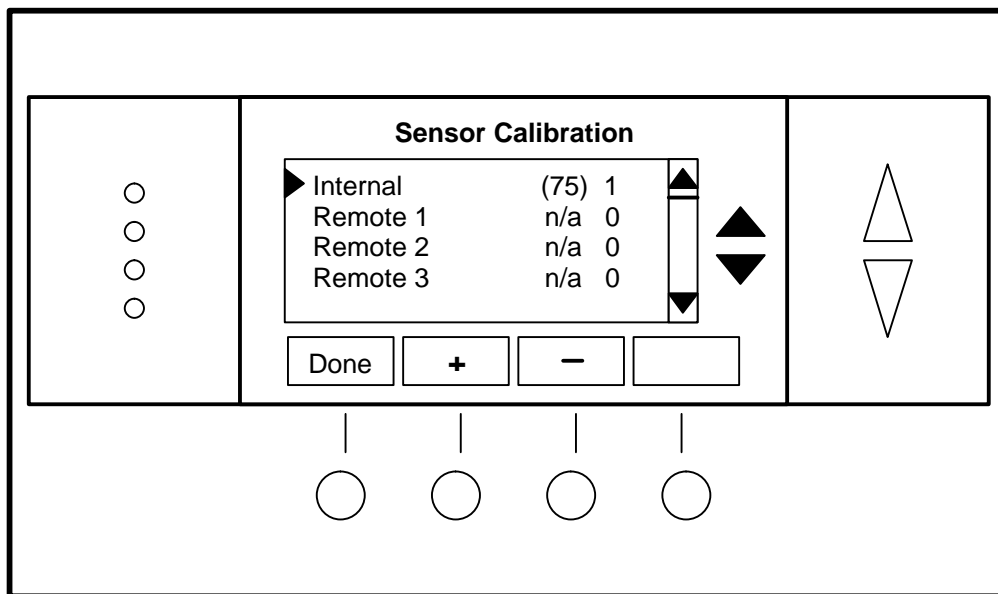

#### Screen navigation buttons:

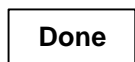

Return to Main Menu Screen

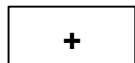

Increase the temperature by 1 deg

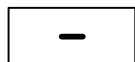

Decrease the temperature by 1 deg

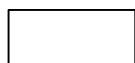

Refresh screen temperatures



Move menu selection pointer up



Move menu selection pointer down

The Backlite/Display screen allows you to set the Backlite ON and OFF brightness levels and contrast.

**Backlite Timeout.** Sets the time from last button press that the backlite will timeout and turn off. Adjustable from 0 or 20 to 45 seconds. If set to “0”, the backlite will never timeout and will always be ON. If set in the range of 20 to 45 seconds, the backlite will turn OFF after the selected time expires.

**ON Level.** Sets the brightness of the backlite when ON. Adjustable in 10% steps, 0 to 100%. If set to “0”, backlite will never be ON. Typically set to 100% for ON.

**OFF Level.** Sets the brightness of the backlite when OFF. Adjustable in 10% steps, 0 to 100%. If you do not want the backlite to go completely dark when OFF, you can set an OFF brightness to something greater than 0%.

**NOTE:** *When you select an ON or OFF brightness, the display changes to that level for you to observe the brightness setting.*

**Contrast.** Sets the contrast level of the LCD display. Adjustable from 0 to 10. Use this control to adjust the darkness of the display. To light and the display looks faded, too dark and dark lines will appear in the display. Typically 5 is the correct setting. Adjust as needed.

### Backlite Settings Screen

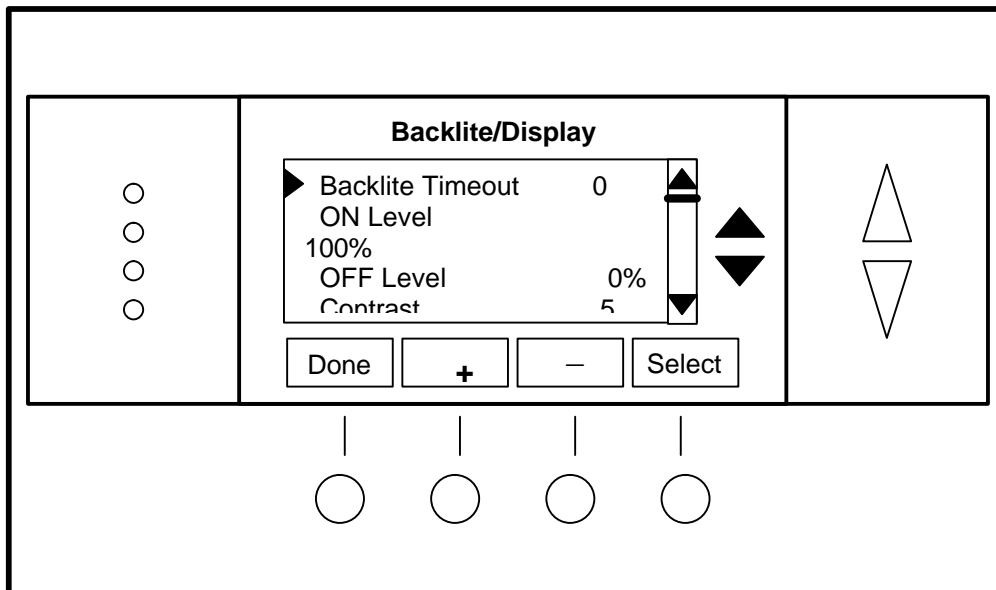

### Screen Navigation Buttons



Return to User Settings menu  
 Increment value  
 Decrement value  
 Not used

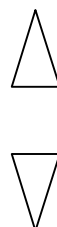

Move menu selection pointer up  
 Move menu selection pointer down

The Thermostat Info screen displays the current configuration of the Thermostat Wall Display Unit and the HVAC Control Unit. This information is useful for quick check of firmware versions and HVAC system setup. It also shows the network address setting.

Thermostat information displayed is:

- **Wall Display Unit** Type and Firmware version number.
- **Control Unit** Type and Firmware version number.
- **System Type** setting: Standard or HP HVAC system
- **Fan Type** setting *for Standard systems*: No Fan w/heat (Gas systems) or Fan w/heat (Electric systems)  
**OR**
- **Changeover** setting *for Heat Pump systems*: Changeover with cool or changeover with heat.
- **Network address** setting: UPB Unit ID: 1 to 250

When finished viewing this screen press the **Done** button to return to the main Menu screen or wait for screen to timeout.

### Thermostat Info Screen

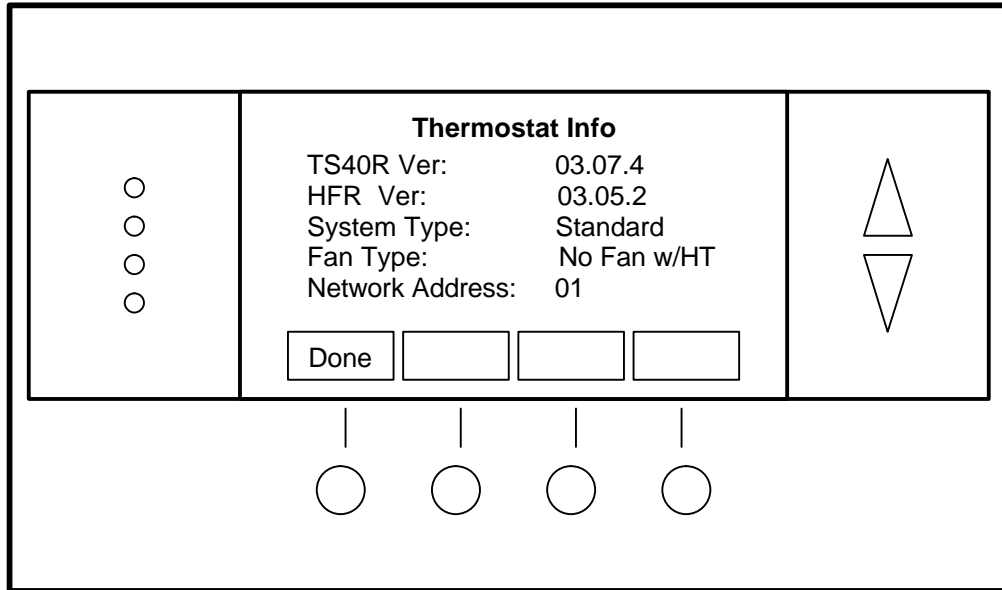

#### Screen navigation buttons:

**Done** Return to Main Menu screen.

The Installer Settings screen is a hidden screen designed for installer use only. Do not change any settings in this screen unless you are a qualified service technician. Changing these settings will affect the operation of the heating/cooling system.

**To enter this screen, go to the main menu selection screen and press and hold the two inner buttons for 3 seconds until the Installer Settings screen appears.**

The Installer Settings screen displays the current internal settings of the thermostat. You can view and change the settings from this screen. Scroll to the desired function and use the +/- buttons to change.

**Display Lock: Y or N                      Default: N**

Y = Display LOCKED

N = Display unlocked

Allows you to lock or unlock the thermostat buttons. When the buttons are locked, you can still access the main menu, but you will not be allowed to select any menu options. The Installer Settings hidden button operation is always operational, allowing you to return to this screen and turn Display Lock off.

**Service Mode Submenu**

**Service Mode: Y or N                      Default: N**

Y = Service Mode On.

N = Service Mode Off.

Sets the thermostat to a test mode with short delays. All runtime and staging delays are reduced to 15 seconds to speed up system checkout and testing.

**Caution: compressor short cycle protection is lost in this mode.**

**Network Settings Submenu \*\*\* DO NOT CHANGE FOR ZWAVE THERMOSTATS \*\*\***

**Network Address: 1 to 254 (0 and 255 are reserved).                      Default: 1**

Sets the serial communications network address.

**Autosend: Y or N                      Default: N**

Y = Autosend On, sends network message when there is a changes in Temp, Setpoints and Mode.

N = Autosend Off. Polled Mode. Only responds to polling requests.

**Max Heat SP 10 to 109                      Default: 109**

Sets the maximum heating setpoint that is allowed. Will not ramp or accept setpoints higher than this maximum.

**Min Cool SP 6 to 110                      Default: 6**

Sets the minimum cooling setpoint that is allowed. Will not ramp or accept setpoints lower than this minimum. **NOTE: this value needs to be reset if you are going to use degree C mode.**

**Minimum Run Time 1- 9 Minutes                      Default: 6**

Sets the minimum run time before a heating/cooling cycle can turn off.

**Minimum Off Time 5-9 Minutes                      Default: 6**

Sets the minimum off time before another heating/cooling cycle can begin.

**Delta T Settings Submenu:**

This is a submenu of the delta, or difference between, the setpoint and current temp for determining when a heat or cool call comes on. Deltas are the number of degrees away from setpoint.

**H/C Delta** – Setting the minimum separation between heating and cooling setpoints. Attempts to lower the cooling below the heating setpoint by this amount will PUSH the heating setpoint down to maintain this separation. Same for setting the heating setpoint above the cooling setpoint will PUSH the cooling setpoint up to maintain this separation. Range is 3 to 15 degrees. Default set to 4 degrees.

**Heat Delta Stage 1 ON**      Range 1 to 8 degrees      Default: 1  
Sets the delta from setpoint that stage 1 heating starts. Stage 1 turns off at setpoint.

**Heat Delta Stage 2 ON**      Range from 1 to 8 degrees      Default: 3  
Sets the delta from setpoint that stage 2 heating starts. Stage 2 turns off at setpoint.

**Heating Delta Stage 3 ON**      Range from 1 to 8 degrees      Default: 5  
Sets the delta from setpoint that stage 3 heating starts. Stage 3 turns off at setpoint.

**Cooling Delta Stage 1 ON**      Range 1 to 8 degrees      Default: 1  
Sets the delta from setpoint that stage 1 cooling starts. Stage 1 turns off at setpoint.

**Cooling Delta Stage 2 ON**      Range 1 to 8 degrees      Default: 3  
Sets the delta from setpoint that stage 2 cooling starts. Stage 2 turns off at setpoint.

#### **WDU Settings Submenu**

**Messaging Enable: Y or N    Default setting: N**

N = "Messages" does not appear in main menu screen

Y = "Messages" appears in main menu screen.

Enables or disables the network messaging function.

***NOTE: If you intend to use the messaging capability of the TS40, you must enable it here by setting to Y. "Messages" will then appear as a menu item in the main menu and you will be able to receive and browse through the messages.***

***INSTALLER SETTINGS CAUTION! Do not change these settings unless you are sure of the effect these changes will make. Changing the network address will make the thermostat not respond if the address is incorrect.***

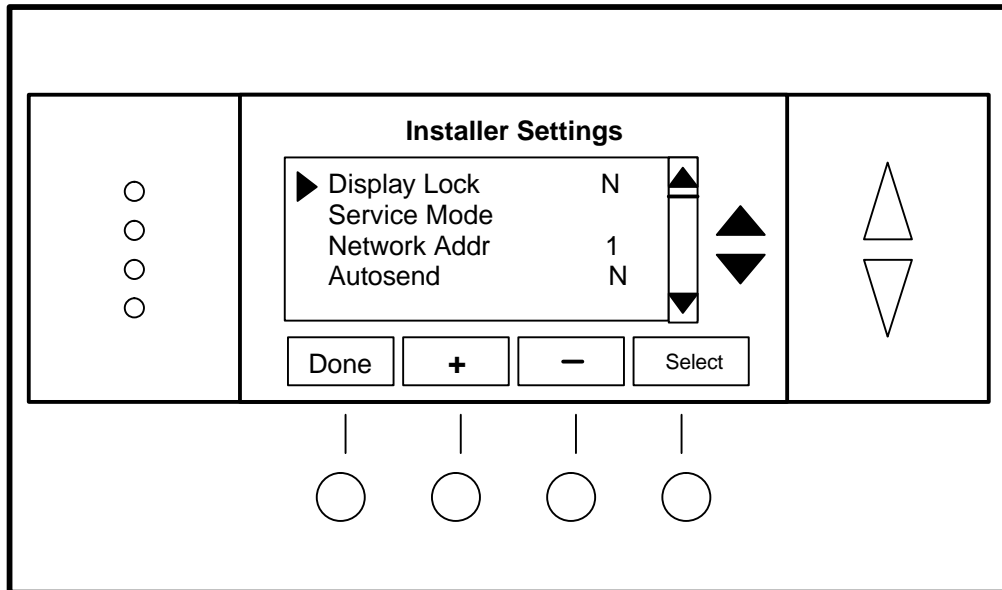

**Screen navigation buttons:**



Return to Main Menu screen



Increase by 1 or change from Y to N

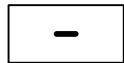

Decrease by 1 or change from Y to N

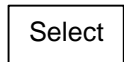

Select menu item to go to a submenu



Move menu selection pointer up



Move menu selection pointer down



**Before proceeding with removing an existing thermostat and installing the TZ40, Read the following important steps.**

1. Record existing wiring information on the enclosed wiring form.
2. Perform the TZ40 bench test
3. Check WDU wiring **BEFORE** applying power to control unit.
4. Be sure to install a freeze protection device as required.

**Installation Overview**

Standard thermostat wiring vs TZ40 in retrofit applications.

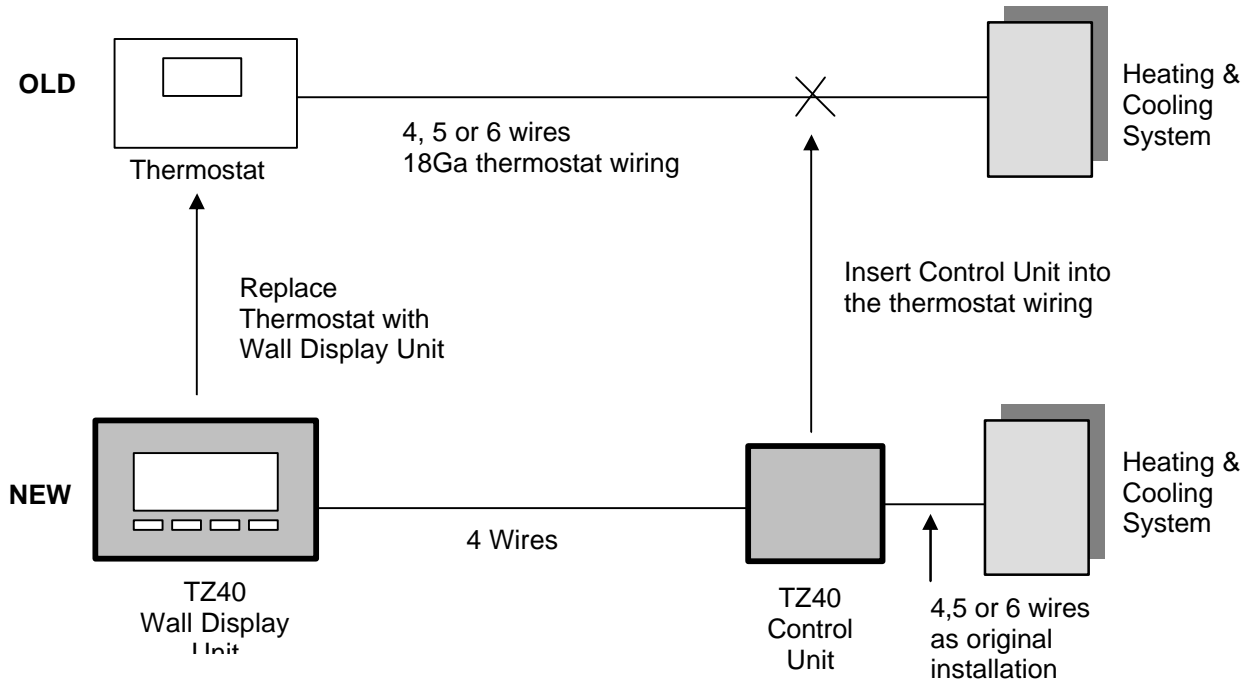

**Freeze Protection.**

In cold climates that require the heating system to be used for building freeze protection, a mechanical backup freeze protection device **MUST** be installed on the heating system. This can be a simple mechanical heating thermostat or a preset thermostwitch installed in the heated area.

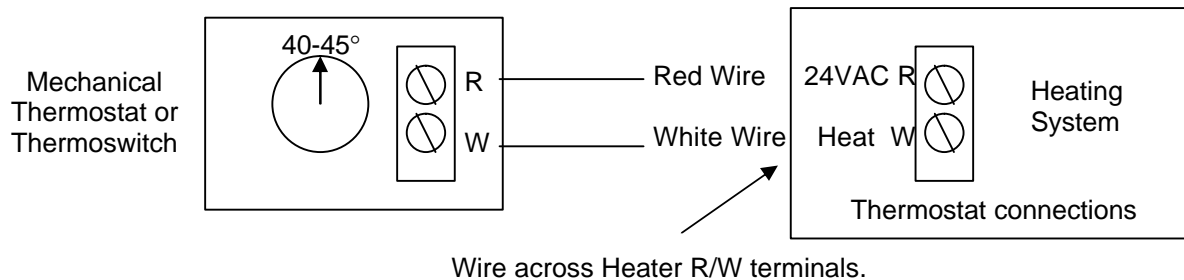

**WDU Location.** Choose a location that best represents the temperature of the area to be controlled. Avoid locations that are subject to drafts, from doors and windows, or areas with direct sunlight exposure.

### WDU Mounting

Route the wires to the WDU through the access hole in the back of the case. Mount the WDU to the wall with the screws and anchors provided. Be sure to plug any large access hole in the wall with sealer or insulation to prevent wall drafts from affecting WDU operation.

### WDU Prewiring

For new construction, the recommended wiring to the WDU from the Control Unit should be a two twisted pair cable, 22 Ga minimum. Use of Category 5 wiring is preferred, but not required. In retrofit applications the existing 18Ga thermostat wiring (a least 4 wires) is adequate and usually will work without problems. However, such non-twisted wiring can be subject to interference due to adjacent in-wall high voltage wiring.

### Wiring the WDU to the Control Unit

Wiring the WDU is simply connecting the four wire cable from the Control Unit to the WDU terminal block. Two wires are for data and two are for power. WDU power is 12VDC and provided by the Control Unit.

**CAUTION: DO NOT MISWIRE THE POWER AND DATA LINES...DAMAGE WILL RESULT!!!  
CHECK YOUR WIRING BEFORE APPLYING POWER...**

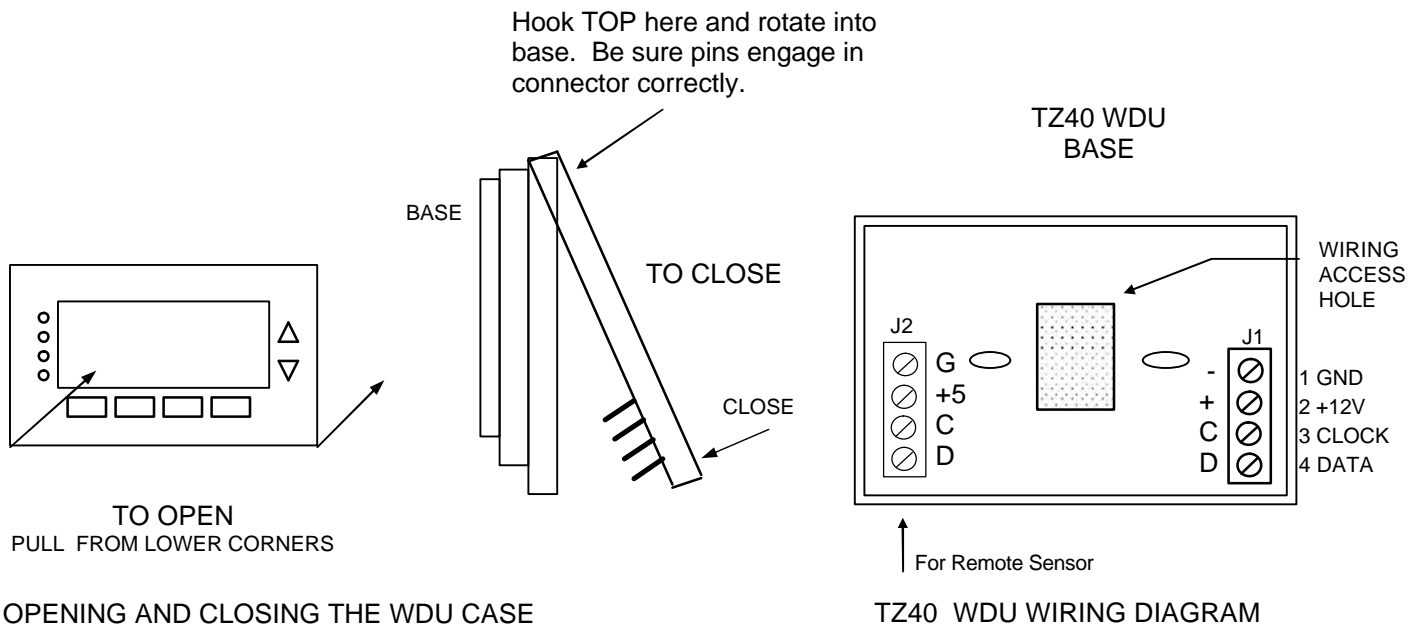

### Remote Sensor Connection

Model TS40 WDU has an remote sensor connector, J2, on the WDU base for connection of an external remote temperature sensor. Follow the wiring diagram with the remote sensor to connect to the WDU.

### Location and Mounting

Install the TZ40 Control Unit in a protected, convenient, INDOOR location near the HVAC system or in a service accessible area such as an equipment closet or garage.

Mount the Control Unit in a vertical position on a wall or sturdy structural member. The unit may be mounted on the HVAC system but care should be taken to avoid the hot burner section or high vibration areas.

### Control unit wiring

The TZ40 HVAC Control Unit is connected to the HVAC system and to the Wall Display Unit as well as the serial communications and power connections.

### Control Unit to WDU wiring

Connect the WDU to the Control Unit with existing thermostat wiring in retrofit installations. For new installs, 22/24 GA twisted pair, typically Cat3 or Cat 5 wiring is preferred.

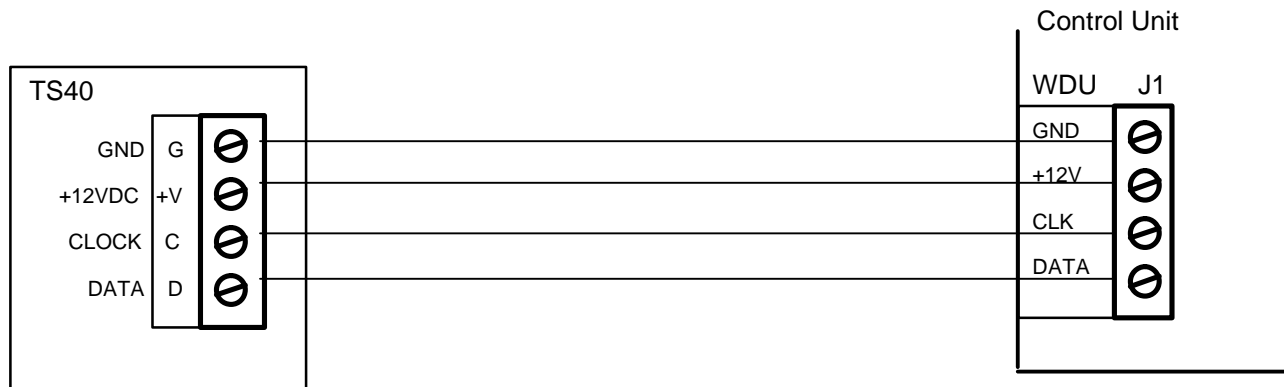

**CAUTION!**

Be careful to not miswire the Wall Display Unit to Control Unit connections as damage may result.

### Control Unit to HVAC System wiring

Electrically, the Control Unit looks like a standard thermostat to your HVAC system. All connections to the HVAC system are made at the normal thermostat connections on the HVAC unit.

You are advised to refer to your HVAC system's documentation for specific information on its thermostat connections and setup requirements. You must know the following:

1. HVAC system type: Gas, Electric, Heat Pump, Radiant, Hydronic
2. Fan requirement: No fan with Heat or Fan with Heat
3. For Heat Pump systems: Changeover with cool or with heat. (O or B connection)

**Note on retrofit wiring.** You may note (and be sure to note on the wiring form) that you have additional wires when you disconnect your old thermostat. Usually these wires are for auxiliary functions such as filter or trouble indicators. For Heat Pump systems there may be emergency heat (EH) wiring or both O and B changeover connections. These wires are not used in the TZ40 installation and, in most cases, these extra wires are not required for normal HVAC system operation.

Refer to the following HVAC wiring diagrams for your type of HVAC system, Standard Or Heat Pump.

**Diagram 1 - Standard Gas or Electric System Wiring**

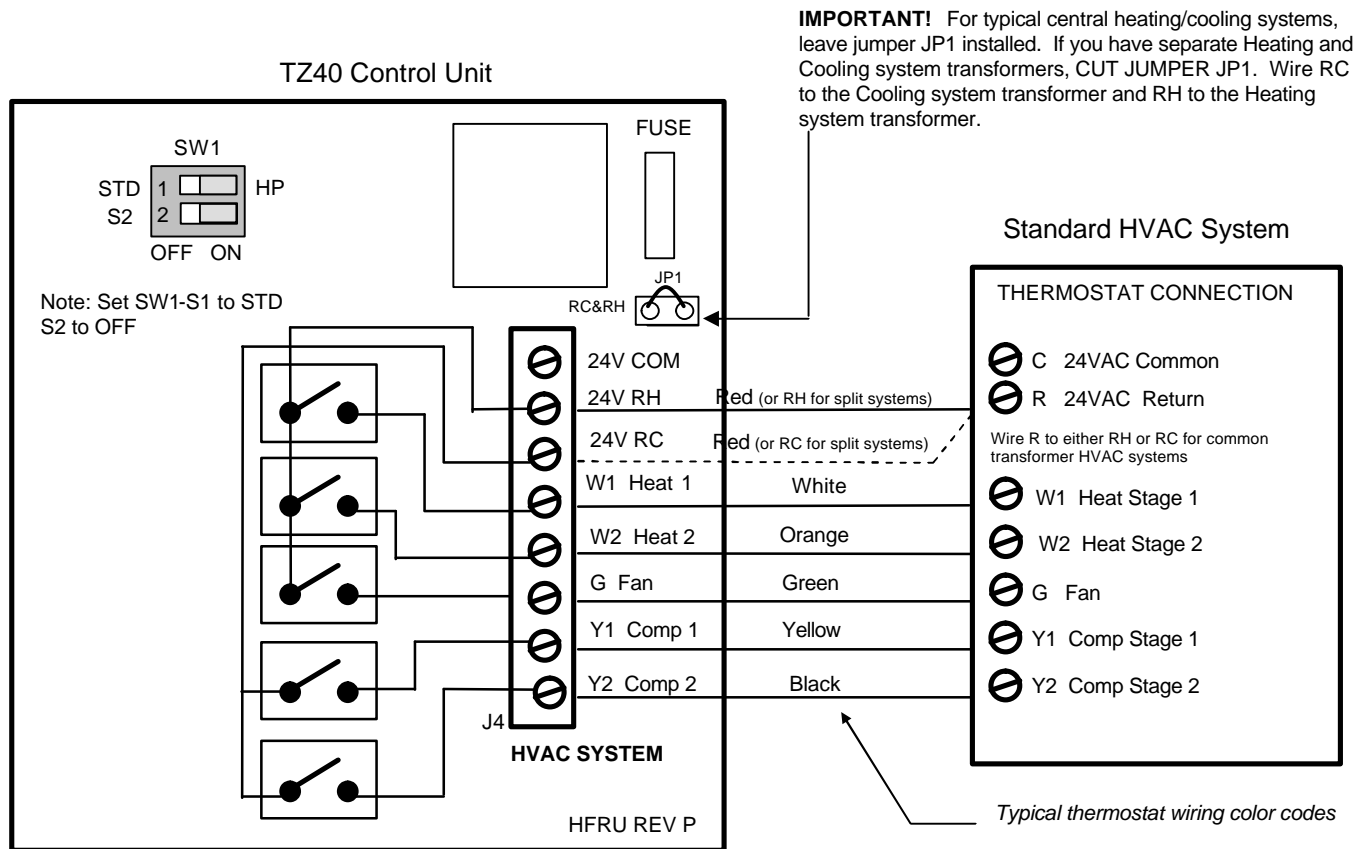

**Standard HVAC System Setup Notes:**

Single Stage Systems use W1 for heating stage 1, and Y1 for cooling stage 1.

Two Stage Heating systems use W1 for stage 1 and W2 for stage 2 heating.

Two Stage Cooling systems use Y1 for stage 1 and Y2 for stage 2 cooling.

**HVAC System 24VAC Transformer**

If you have an integrated heating and cooling system with a single transformer, **do NOT cut jumper JP1**. Wire the 24V Return (red) wire to either RH or RC. This is typical of most central systems.

If you have separate heating and cooling systems with separate transformers, **cut jumper JP1**. Wire the heating 24V R (red) wire to the control unit's RH terminal and run the cooling systems 24V R (red) wire to control unit's RC terminal. Also wire the cooling systems 24VAC Com to the control units 24VAC Com terminal.

**Dipswitch SW1 Setup for Standard HVAC Systems**

1. Set SW1-1 (position 1) to the STD position. (Off - to the left) (default setting)
2. Set SW1-2 (position 2) to the correct setting for your HVAC system.
  - a. **Gas furnaces** do not require fan outputs for heating calls. Set SW1-2 to the Off - to the left. (default)
  - b. **Electric furnaces** do require fan outputs for heating calls. Set SW1-2 to the On - to the right.

Diagram 2 - Heat Pump System Wiring

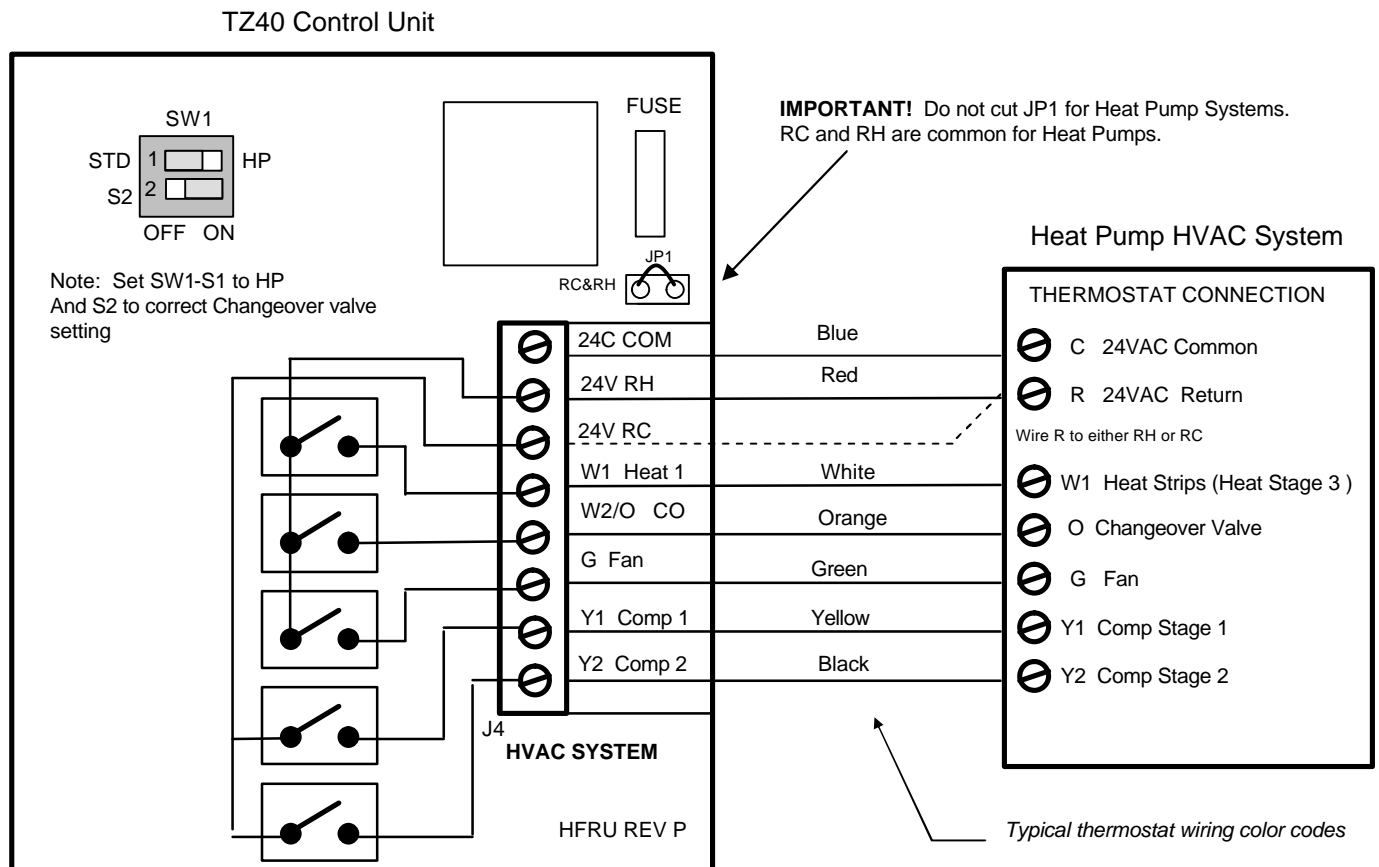

Heat Pump HVAC System Setup Notes:

Single Stage Compressor Systems use **Y1 for stage 1** heating/cooling, and **W1 for stage 2** heating (heat strips).

Two Stage Compressor Systems use **Y1 for stage 1**, **Y2 for stage 2** heating/cooling, and **W1 for stage 3** heating (heat strips).

**NOTE:** You must configure the Changeover valve setting to work correctly with your HVAC system. Set Dipswitch SW1 as below for correct changeover operation. Changeover with cool is typical for most systems. Check your system information to be sure. If you get cooling when you expect heating, change SW1-S2 to the other position.

**Dipswitch SW1 Setup for Heat Pump HVAC Systems.**

- Set SW1-1 (position 1) to the Heat Pump position. (On - to the right)
- Set SW1-2 (position 2) to the correct changeover (reversing valve) setting for your Heat Pump system.
  - For systems with changeover with cooling, Set SW1-2 to Off - to the left (default setting)
  - For systems with changeover with heating, Set SW1-2 to On - to the right

## TZ40 Power Connection

The TZ40 Control Unit requires 24VAC power from the HVAC system it is controlling. Connect the 24VAC Common (Blue wire/terminal) and 24VAC R (Red wire/terminal) from the HVAC system to the control unit's HVAC System terminal block J4's 24VCom and 24V RH **or** 24V RC terminals (the RH and RC terminals are default jumpered together...see below)

### **Common or Split Transformer Systems**

Most HVAC systems have a common heating and cooling transformer. Connector JP1 is jumpered to common the RH and RC inputs together for this configuration. If you have a system with separate heating and cooling transformers, you will need to split the RH and RC jumper by cutting the JP1 jumper.

When wiring split systems, wire the heating systems 24VAC R (red wire) to the Control units RH terminal, and wire the cooling systems 24VAC R to the control units RC terminal. Also wire the cooling systems 24VAC Com to the control units 24VAC Com terminals.

# TZ40 ZWave Adapter

The TZ40 comes with an external ZWave adapter (ZWB) that connects to the TZ40 RS485 port. The RS485 port is dedicated to the ZWave adapter and cannot be used for other communications.

NOTE: DO NOT CHANGE THE DEFAULT RS485 ADDRESS OF THE THERMOSTAT (SET TO 1).

The TZ40 supports the standard ZWave protocol for thermostats.

Connect the adapter as shown and proceed with enrolling the device into your ZWave network.

## ZWB ZWave Thermostat Adapter Wiring

1. Place the ZWB in a convenient location that gets good ZWave reception. You must have access to the ZWB module to set the ZWave network address.
2. Connect the ZWB to the TZ40 HVAC control unit with 22-24Ga wiring. (Category 3-5 wiring acceptable). Wiring can be up to 1000ft.
3. Connect the D+, D- and Gnd terminals on the ZWB module to the RS485 connection on the TZ40 control unit.
4. Connect the 12V terminal on the ZWB to the 12V terminal on the WDU terminal on the TZ40 control unit.
5. Power up TZ40 HVAC control unit and observe that the ZWB Power LED is on.
6. Enroll the ZWave adapter in to the ZWave network using a ZWave network remote or other control system interface.
7. Confirm ZWave message traffic with the Network LED.

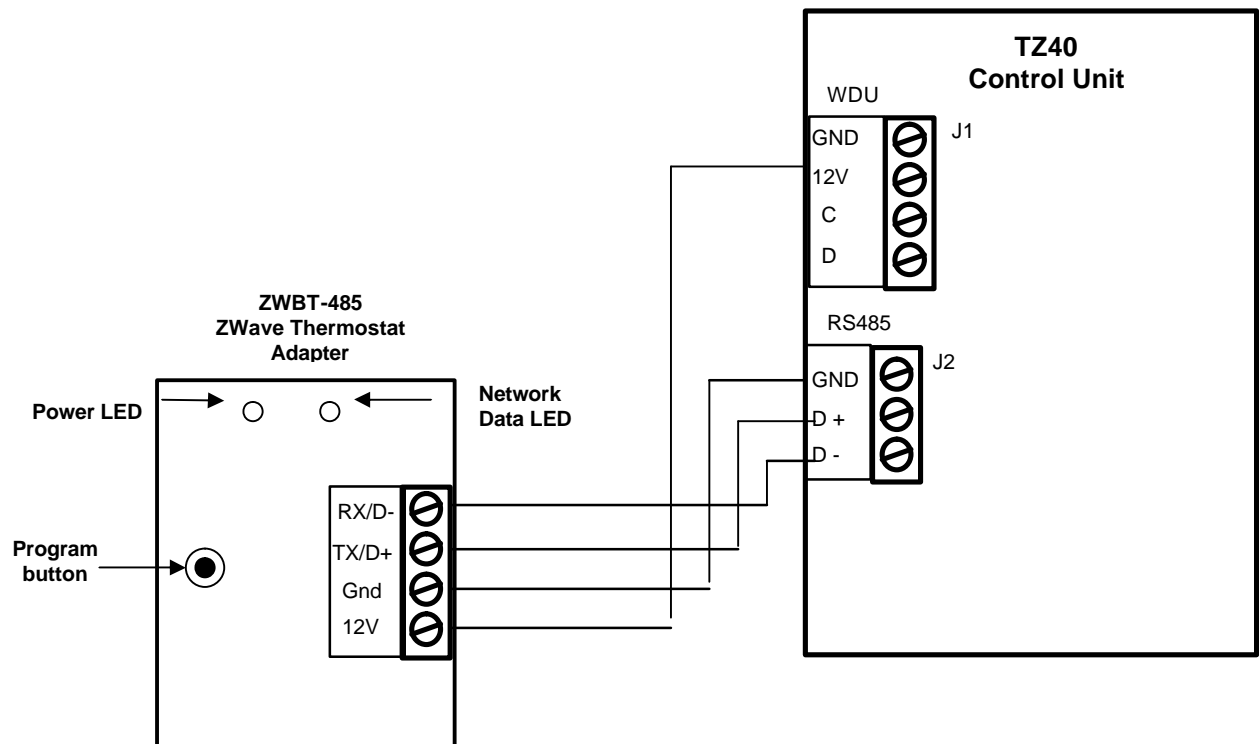

It is strongly recommended that you hook-up and run a simple bench test before installing the TZ40. Not only will this save you time in system checkout but will also familiarize you with the thermostat's operation.

### THERMOSTAT BENCH TEST

1. Connect the Wall Display Unit to the Control Unit with a short (12-24 inch) 4 wire cable.
2. Before power up, set the Control Unit dipswitch, SW1, to ALL OFF
3. Connect power to the Control Unit.
4. Verify Control Unit Status LED is blinking.
5. Verify the WDU display comes on and shows the current temperature.
  - a. If no display and backlights are not on, check wiring and power at the Control Unit.
  - b. If a "CF" display is shown on the WDU, double check your wiring to the Control Unit.
  - d. Do not proceed until the current temperature is displayed on the WDU.
6. With the current temperature displayed on the WDU, we have verified communication between it and the Control Unit is OK. Any communication problems will result in a "CF" (Communications Failure) display on the WDU and must be fixed before proceeding. If all is OK with the WDU proceed to the next step.
7. Press the Fan button on the WDU. The Control Unit's Fan LED and relay should turn on.
8. Press the Fan button again. The Fan LED and relay should turn off.
9. Press the Mode button until the WDU is showing "H" for Heat Mode.
10. Press the Setpoint Up button until the setpoint is above the current temperature. The Heat LED and relay should come on. (If they don't, make sure the Status LED is not flashing twice indicating minimum off delay...wait until LED stops flashing twice before proceeding).
11. Press the Mode button until the WDU is showing "O" for OFF. The Heat LED and relay will turn OFF.
12. Wait 6 minutes for the minimum off delay to expire. The Status LED will stop flashing twice.
13. Press the Mode button until the WDU is showing "C" for Cool Mode.
14. Press the Setpoint Down button until the setpoint is below the current temperature.
15. The Compressor and Fan LEDs and relays should turn on.
16. Press the mode button until the WDU is showing "O" for OFF Mode.
17. All LEDs and relays should turn off.
18. When you have successfully completed all these tests, you have verified that the TZ40 is working correctly.

## HVAC System Testing

If you have difficulty with the HVAC system operation, you can perform the following test to verify the HVAC system is operational.

Thermostats, like the TZ40, are just switches to the HVAC system as shown in the diagram below. This is a simplified example of a thermostat and a standard HVAC wiring diagram. The HVAC system operation can be tested by duplicating the thermostat switch operation by shorting across the thermostat terminals on the HVAC system.

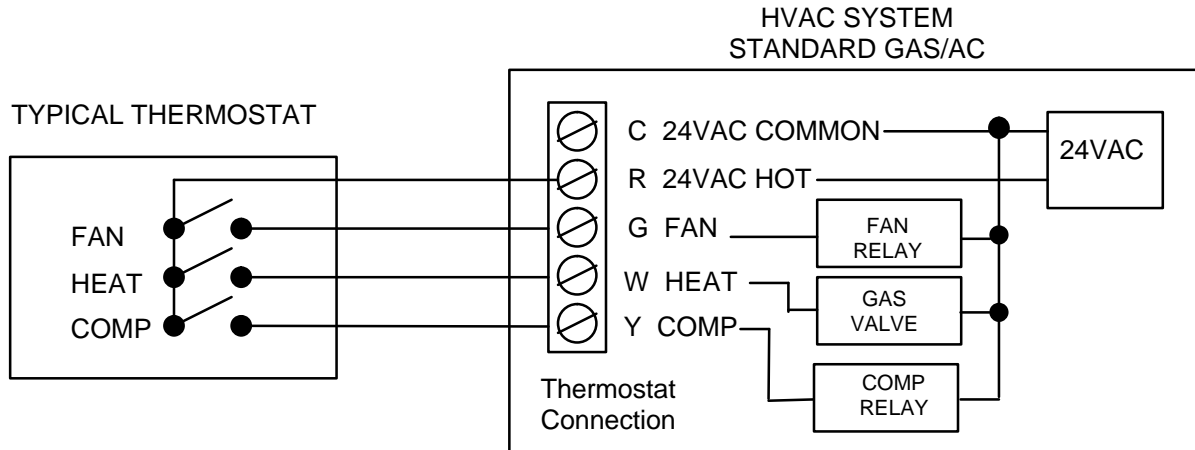

**Note:** The HVAC system and thermostat connection voltage is 24VAC. This is a safe voltage to work with but be careful to avoid shorting the 24VAC common (C) and 24VAC return (R) terminals. This may blow a fuse in the HVAC system.

### Standard HVAC System Quick Test

You can perform a quick test of the HVAC system by shorting across the appropriate thermostat terminals on the HVAC thermostat connector. Use a short 6 inch wire to connect across the following terminals.

Function Test	HVAC Terminals	Result
Fan	R to G	Fan should come on
Heating	R to W	Heat cycle should start for heating
Cooling	R to Y and G	Compressor and Fan should start for cooling

### Heat Pump System Quick Test

Similarly, you can test Heat Pump operation by shorting across the following terminals. Heat pump operation is determined by compressor calls in conjunction with changeover (O) outputs. You must know what your system CO type is (CO with Cool (typical) or CO with Heat). You should have configured the TZ40 control unit for correct CO type, refer to this setting. Heat Pump systems have an additional O terminal.

Function Test	HVAC Terminals	Result
Fan	R to G	Fan should come on
Heating	R to Y and G	Compressor and Fan should start and Heating occurs.
Cooling	R to Y and G and O	Compressor and Fan should start. CO valve operates and Cooling occurs.

Note: if you have the CO selection incorrect you will get cooling when you expect heating and vice versa. Change the dipswitch SW1-2 changeover setting to correct this problem.

TZ40 CONTROL UNIT

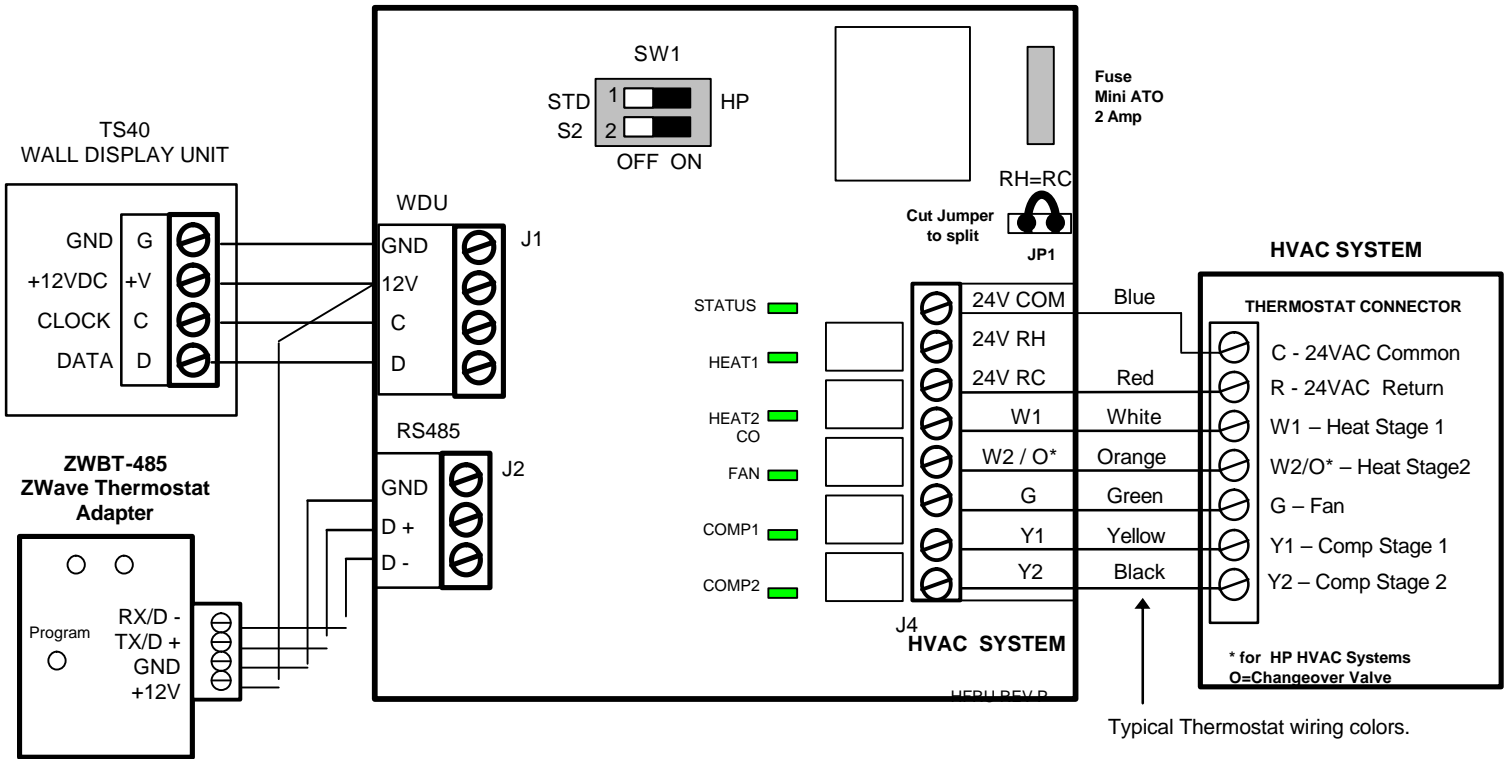

**HVAC System Transformer:**

Most central HVAC systems have a common heating and cooling transformer. This is the factory default setting for Jumper JP1. In some cases, you may have separate heating and cooling systems, each with their own transformer. In that case, **cut Jumper JP1** and wire the heating transformer red wire to the RH terminal and the cooling system transformer red wire to the RC terminal. Wire the cooling system's 24VAC Com to the control unit's 24VAC Com terminal.

**Dipswitch SW1 Settings: (White is switch position)**

**SW1-S1, STANDARD OR HEAT PUMP SYSTEM SELECTION**

HVAC Systems can be either Standard Gas/Electric systems or Heat Pump systems.  
 Set S1 to STD SYS (OFF) for Gas/Electric systems (default setting).  
 Set S1 to ON for Heat Pump systems

**SW1-S2 Fan or Change Over Valve Selection**

If S1 is set to Off for Standard HVAC systems, then S2 selects the HVAC **fan type**.  
 Set S2 to OFF for gas systems that do not require Fan w/heat calls.(default setting)  
 Set S2 to ON for electric systems.

If S1 is set to On for HP HVAC systems, then S2 selects the **changeover or reversing valve type**.  
 Set S2 to OFF for changeover with cooling (default setting).  
 Set S2 to ON for changeover with heating