

Model TU16 UPB Thermostat

INSTALLATION AND OPERATION MANUAL

Rev P HVAC Control Unit

Rev 6

10/22/07

DCN: 141-01435-06

This revision of the document applies to the following part numbers and revisions or later.

Product	Rev	Part No	Firmware
TU16 Thermostat	P	001-01435-07	
TS16 Wall Display Unit	G	001-00910-13	TS16v353
HFUP HVAC Control Unit	P	001-01434-07	HFUP0123

***** IMPORTANT NOTICE *****

**DO NOT USE THIS PRODUCT FOR BUILDING FREEZE PROTECTION! YOU ARE ADVISED TO
INSTALL A MECHANICAL FREEZE PROTECTION DEVICE FOR THIS PURPOSE.**

TU16 Operation

The TU16 thermostat provides the latest technology in a full-featured universal thermostat with UPB powerline communications. The TU16 has many unique features including:

- Separate Heating and Cooling setpoints
- Multistage HVAC systems support
- Wall Display Unit setting of
 - UPB Network and Unit ID
 - F/C temperature display mode
 - Sensor calibration (internal and remotes)
- Automatic Remote Sensor detection
- AutoSend Mode for easy network communication
- Enhanced two way UPB protocol
- Supported by UPStart installation tool

The TU16 thermostat consists of two parts, a **Wall Display Unit (WDU)** and a **HVAC Control Unit**. Also required is a UPB Powerline interface module.

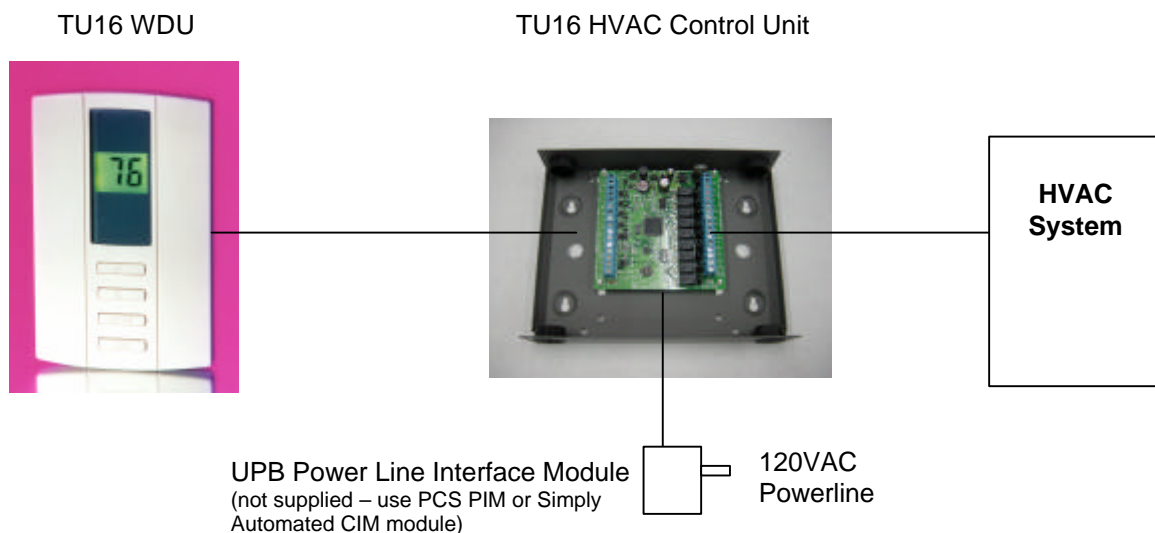

The Wall Display Unit provides users functions like a traditional thermostat and connects to the Control Unit by a 4 wire cable. The Control Unit connects at the HVAC system using the standard thermostat connections and provides the thermostatic temperature control of the system. The Control Unit also has the UPB powerline network connection via a UPB CIM or PIM powerline interface module.

The TU16 has separate heating and cooling setpoints. The display shows the setpoint of the current operating mode (in Auto mode, the system keeps track of the current operating mode of the last call, either heating or cooling).

In addition to the universal Standard or Heat Pump HVAC systems support, the TU16 has multistage heating/cooling system outputs. The control unit can support 2 stages of heating and cooling for Standard systems. It supports 3 stages of heating and 2 stages of cooling for Heat Pump systems.

The TU16 has a convenient setup mode from the Wall Display Unit. You can set the UPB Network and Unit IDs, degree F or C display mode and easily calibrate the internal and all attached remote sensors.

The TU16 has automatic detection and setup of remote temperature sensors. Remote sensors have address settings that, when detected by the TU16, will be used for specific functions, such as, in place of the internal sensor or averaging with remote sensors.

Universal Power Bus (UPB) is a power line communications technology used by many products such as lighting controls. The TU16 use the same UPB power line communications to provide a robust two way communication protocol that allows for full control and monitoring of the thermostat.

The TU16 provides the ability to communicate via the standard UPB protocol. You must select some third party control system or software package that enables UPB communications to the thermostat.

Be sure to verify that the system you select is compatible with the RCS TU16 UPB thermostat.

The TU16 supports two modes of UPB communications: Link Mode or Message Mode commands.

Link mode is a simplified on/off protocol used by lighting switches to create scenes. Message mode is a more robust bi-directional communications that is used by host control systems to send commands to, and receive data from, the thermostat.

Simplified thermostat control by Link Commands

Link commands can be generated by simple UPB standalone transmitters. Used by lighting devices, it enables multiple devices to be a member in a "scene". UPB supports 250 Link commands.

For simple, direct, one-way (no status) control of the thermostat, it comes with a set of link commands predefined to control HVAC system mode (Off/Heat/Cool) and a limited range of setpoints. Thus, a UPB hand held 8 button remote can generate 16 link commands (activate/deactivate). These can be mapped into thermostat commands. Refer to the Link Mode section for more information on this method of operation.

Caution: *When using the TU16 on the same network ID as lighting devices, be aware that lighting links can trigger thermostat operation if the lighting link command range overlaps the thermostat link range. You must keep lighting link and thermostat link commands separated. The thermostat links are default set to links 200 to 235. If you are not using the thermostat in link mode, it is recommended that you DISABLE link commands.*

Message Mode

The TU16's Message Mode takes advantage of UPB's ability to send actual messages over the power line. This allows for a two way communications protocol and provides the ability to not only change the thermostats setpoints and modes, but to also read back the thermostat temperature, setpoint and mode settings.

NOTE: *the TU16's UPB Message Mode two way operation can only be used with control systems that have built-in support for this device. Be sure to confirm with the control system manufacture that support is available for the RCS TU16 before attempting to use it. SYSTEM SUPPORT FOR UPB ALONE IS NOT ASSURANCE THAT THE SYSTEM HAS BEEN PROGRAMMED FOR USE WITH THE TU16.*

UPB Address Setup

Like all UPB devices, the TU16 has a UPB address consisting of a **Network ID** and a **Unit ID**. These ID's can be set via the Wall Display Unit or by the UPB **UPStart** program. Some control system software can also directly set the UPB address of the thermostat. Refer to the **UPB Installation** section of this manual for address setting instructions.

TU16 default UPB Network and Unit ID:

Network ID:	255
Unit ID:	249
Password:	1234

TS16 Wall Display Unit

The TS16 Wall Display Unit has a LCD display and control buttons for changing the setpoint, system operating mode and manual fan mode. The WDU also has an internal temperature sensor. The display serves as a common display for many functions. It normally shows the current room temperature but switches to show setpoint, mode or other functions when buttons are pushed. Two on-screen indicators show the state of the manual fan and setback mode.

Any changes, such as the temperature or control button operations at the WDU are sent to the HVAC Control Unit. In turn, the Control unit sends changes in setpoint or modes from the serial communications network to the WDU. When updates are received by the WDU, they are displayed on the LCD display for 3 seconds and then the display returns to the current room temperature.

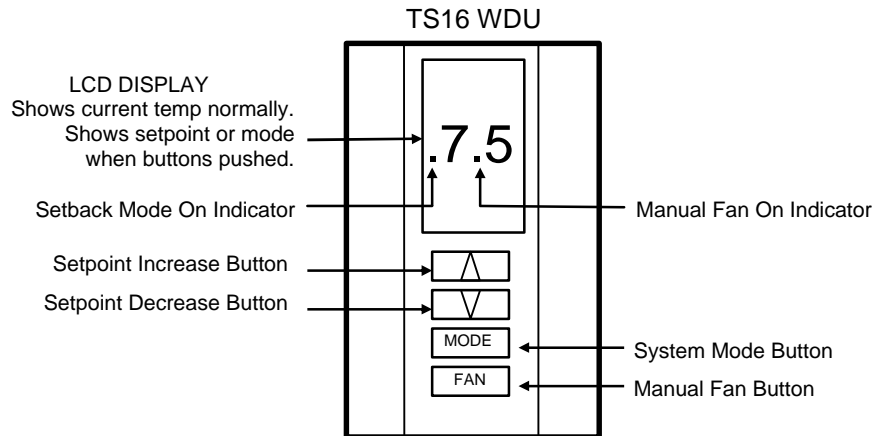

LCD Display

The LCD display is a two digit multifunction display that normally shows the current room temperature. It has a continuous backlight for easy viewing anytime. Whenever any of the control buttons are pushed, the LCD display will change to show that function's current status. The LCD display will stay in the new display mode as long as buttons are being pushed. After 3 seconds of no activity, the display will change back to show current temperature.

The right decimal point on the LCD display will turn on whenever manual fan is ON. The left decimal point will flash whenever the setback mode is ON.

Remote changes in setpoint or modes that are received by the WDU from the Control Unit will cause the LCD display to switch and display the updated data for 3 seconds and then return to room temperature.

Temperature Display

The WDU will normally display the room temperature from the internal digital temperature sensor or a remote sensor if attached.

The WDU will display temperatures from -9°F/C to 127°F/C. Temperatures less than 0° will be displayed down to -9 ° as negative numbers. Temperatures below -9 will also be displayed but no minus sign can be displayed. Temps over 100° will be displayed without the leading 1 (ex: 102 will be displayed as 02°.)

Outside Temperature Display

If you attached a remote temperature sensor to the WDU that is set to remote sensor address "4", you can view this outside temperature by **pressing the UP and DOWN buttons simultaneously**. Outside

temperature data may also be sent to the WDU via network commands and viewed this way. Note if you press the UP/DOWN buttons and no temperature information is available, the display will show “- -”.

Control Buttons

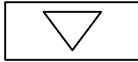
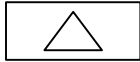

Setpoint UP and DOWN Buttons

The **UP** and **DOWN** buttons control the heating or cooling setpoint temperature.

To View The Current Setpoint: Push either the **UP** or **DOWN** buttons **once** will cause the LCD display to change to **show** the current setpoint temperature (but won't change it).

To Change The Setpoint: With the setpoint displayed as above, push the UP button to increase the setpoint temperature by one degree or push the DOWN button to decrease the setpoint by one degree. Pushing and holding a button down will cause the setpoint to continuously ramp up/down until the button is released. After 3 seconds of no activity, the LCD display will change back to show the current room temperature and the new setpoint value will be sent to the Control Unit.

NOTE: *You cannot change the setpoint when in the OFF mode.*

Setpoint Display

The displayed setpoint shows the setpoint of the **current operating mode** (heating or cooling) of the system. If you change modes, the setpoint displayed will change to the new operating mode setpoint.

If you set the mode to AUTO mode, the setpoint displayed will be the current operating mode of the system, either heating or cooling. This will change if the operating mode changes automatically.



MODE Button

The **MODE** button sets the HVAC system Heating or Cooling mode.

To View The Current Mode: Push the **MODE** button **once** and the LCD display will change to **show** the current mode.

To Change The Mode: While the mode is being displayed, pushing the **MODE** button again will go to the next mode. The system mode cycles from **Off** to **Heat** to **Cool** to **Auto** and back to **Off** again with each push of the **MODE** button. Once you stop pushing the button (for 3 seconds) the new mode will take effect and the display will change back to room temperature.

When Heat Pump HVAC system type is selected on the Control Unit dipswitch, an additional system mode of “**EH**”, or Emergency Heat, is included in the TS16 mode selections. EH is used when Heat Pump compressor failure requires the use of Auxiliary Heat (heat strips) for primary heating. When EH mode is selected, the display will alternate between current temperature and “EH” to remind you that the EH mode has been selected.



FAN Button

The **FAN** button controls the HVAC system's manual fan mode. Pushing the **FAN** button once will turn the fan **ON** and pushing it again will turn the fan to the **AUTO** mode (which is OFF unless the fan is automatically turned ON by the heating or cooling operation). The decimal point in the middle of the two digits on the LCD display will come on when the manual fan is ON. Changes in the fan mode will be sent to the HVAC Control Unit.

System Setup Mode

The TU16 has a setup mode to allow the user to set the following functions from the WDU:

- UPB Unit ID address (also Network ID when in UPB Setup Mode)
- F/C mode
- Sensor Calibration

Entering into the setup mode.

Enter the setup mode by the following procedure:

1. First press and hold the Mode button
2. Simultaneously press the Fan button.
3. The display will change to show "SU".
4. Release all buttons.
5. The display will change to show the setup menu, starting with "Ad" (address)
6. Select what setup function you want to change or view by pressing the Mode button to cycle through the menu options:
 - "Ad" = UPB Unit ID address
 - "FC" = Fahrenheit or Celsius mode
 - "C1" = Calibrate Internal Sensor (or Remote Sensor address 1 if attached) and if additional external sensors are attached they will appear also:
 - "C2" = if Remote Sensor address 2 attached

Viewing the UPB Unit ID Address

When you first enter the setup mode, the first menu selection displayed on the LCD display is "Ad". To view the current address setting, press the UP or DOWN button once. The current UPB Unit ID will be displayed.

Note: The TU16 has a two digit display, so addresses beyond 99 are display using the decimal points as range indicators. For example:

Range 1-99	Display: 0 1	address = 1	(no decimal)
Range 100-199	Display: 0.1	address = 101	(middle decimal)
Range 200-255	Display: .0 1	address = 201	(left decimal)

Setting the Unit ID address

With the current address displayed, press the up or down arrow buttons to change the address as desired.

To exit the address mode, press the mode button again or wait for the screen to time out (5 seconds).

SEE THE UPB INSTALLATION SECTION FOR MORE INFORMATION ON ADDRESS SETTING.

Setting the Fahrenheit or Celsius degree display mode

In the setup mode, press the mode button until "FC" is displayed. Press the UP or DOWN arrow once to display the current setting. While the current mode is being displayed, you can press the UP/DOWN buttons to select F or C as desired. To exit, press mode again to move to another setup mode or wait for the screen to time out and return to the normal thermostat temperature display. The TU16 is default set to F mode.

Setting the Sensor Calibration

The internal temperature sensor and all attached remote sensors can be calibrated or adjusted +/- 7 degrees as desired. In the setup menu, press the mode button until C1 is displayed. This is the internal sensor (or remote sensor address 1 if attached). Press the UP or DOWN arrow once to display the current calibration setting (offset, see below for more calibration information). Press UP/DOWN buttons to set the calibration offset desired. If there are more remote sensors attached, they will show up as C2 or C3.

Exit setup mode

When you are done making changes and no button is pressed for 5 seconds, the display will automatically exit setup mode and return to the thermostat mode and current temperature display.

Temperature Display Calibration

The TS16 WDU has the capability for the user to adjust the temperature display calibration of the internal sensor as well as all attached remote sensors from the WDU in the setup mode.

Normally the TS16, with no attached remote sensors, will only show the internal sensor as “C1” in the calibration setup menu. The TS16 can have additional remote sensors attached. These are addressed as remote sensors 1 and 2. If they are detected by the TS16, they will show up in the calibration menu as additional sensors to calibrate as C1 and C2. Note that if remote sensor with address 1 is attached it replaces the internal sensor and becomes the “C1” sensor. See the remote sensor section for more details.

When the desired sensor is selected in the setup menu, you can adjust its displayed temperature calibration up or down 7 degrees by pressing the UP/DOWN buttons.

The calibration menu selections are:

C1 = calibrate internal sensor or remote sensor address 1 if attached

C2 = calibrate remote sensor address 2 (only shows up in menu if attached)

Remote Sensors

The TS16 Wall Display Unit has a remote sensor terminal block, J2, on the base for connection of a remote temperature sensor. Remote sensors have an address that can be set to 1, 2, or 4. Without any remote sensor attached, the WDU uses the internal sensor for the current temperature information. When a remote sensor is attached, the WDU will detect it *automatically* and will use the remote sensor(s) according to its address selection. Modes of operation are as follows:

Address 1: Use this remote sensor instead of the internal sensor. (becomes C1 in the calibration setup).

Address 2: Average remote sensor 2 with internal sensor or sensor address 1 if attached. (C2)

Table of Remote Sensor Functions and Sensor Addresses

Not Remote Sensors attached	Internal sensor only is used	Display is internal sensor temp
Remote Sensor Address 1 only	Internal sensor is not used	Display is remote sensor 1 temp
Remote Sensor Address 2 only	Average temps of sensor 2 with internal sensor	Display is average of internal and remote sensor 2 temps
Remote Sensors 1 and 2 attached	Average temps of sensor 1 and sensor 2	Display is average of sensor 1 and sensor 2 temps

When averaging sensors are used, the **average** temperature is displayed on the WDU and reported to the HVAC control unit. You cannot view an individual remote averaging sensor temperatures as the main thermostat display or report individual sensor temperatures on the communication port. However, you can check the individual sensor temperatures by going to the calibration setup menu and selecting the sensor address.

“CF” or “SF” Error Displays

If the WDU is not properly wired or if communications to the Control Unit is interrupted, the LCD display will display “CF” to denote Communication Failure. Momentary display of “CF” caused by bad or lost data, will clear automatically when data communication is restored.

If the “CF” continues to be displayed, check wiring for problems. A continuous “CF” display may indicate a problem with the Control Unit or the WDU itself.

An “SF” display indicates a temperature sensor failure. If this is displayed continuously, the sensor is failing to respond and must be replaced. This can also be displayed when attempting to view the outside temperature if this sensor has failed or been disconnected.

TU16 HVAC Control Unit

The TU16 HVAC Control Unit works in conjunction with the Wall Display Unit to provide thermostatic control of the HVAC system. In addition, the Control Unit can receive UPB powerline commands for remote control of the heating/cooling setpoints and mode of the thermostat. The TU16 can also report various status information via the UPB powerline network.

The TU16 Control Unit connects to the HVAC system the same as, and in place of, a standard thermostat. It is usually mounted near the HVAC system, although it can be mounted anywhere convenient. It is connected to the WDU by a 4 wire cable, either standard thermostat wiring or typically Cat 3/5 in new construction.

Actual thermostatic control of the HVAC system is provided by the Control Unit. Changes in the current temperature, setpoint, system or fan modes are sent to the Control Unit either from the WDU or via UPB commands. The Control Unit monitors this information and operates the HVAC system accordingly.

HVAC System Compatibility

The TU16 works with almost all heating and cooling systems, including standard Gas/Electric, Heat Pump, Radiant, or Hydronic systems and with single or multi-stage systems. Compatible with single or separate transformer heating/cooling systems (Note: one stage heat only for split heat/cool transformers).

System Type	Heating Stages	Cooling Stages	Notes
Gas	2	2	Single or split transformer
Electric	2	2	Selectable Fan with Heat
Heat Pump	3	2	Selectable Changeover with Heat or Cool

STANDARD GAS/ELECTRIC HVAC SYSTEMS OPERATION

The TU16 has typical HVAC system operating modes of Heating, Cooling and Auto changeover.

In addition to the multiple stages, the TU16 has adjustable temperature difference (**delta**) between stages and an adjustable **deadband** between heating/cooling setpoints. These control unit variables can be changed via network commands. The examples below are based on the default settings.

In the **HEAT** mode, the stage 1 heating will be turned on at one degree below the heating setpoint and will turn off **at** the setpoint. In the **COOL** mode, the stage 1 cooling will be turned on at one degree above the cooling setpoint and will turn off **at** the setpoint. This is referred to as the setpoint delta. It is default set to 1 deg but can be changed via network commands.

Second stage heating/cooling deltas are factory set at 3 degrees. This means that second stage will come on when the delta from setpoint reaches 3 degrees. Second stage heating/cooling calls will stay on until the first stage setpoint is satisfied.

In the **AUTO** mode, the system will maintain the heating or cooling setpoints and switch automatically from heating mode to cooling mode as needed. There is a **deadband** between heating and cooling setpoints that keeps the two setpoints from overlapping. This is default set to 4 degrees, but can be changed.

Setpoint Push. If you adjust the heating setpoint to be less than 4 degrees from the cooling setpoint, the cooling setpoint will be **pushed** to maintain the 4 degree deadband separation. Same for adjusting the cooling setpoint, if you get within the deadband separation, the heating setpoint will be pushed.

Minimum Run Time (MRT). The HVAC control unit has a minimum run time that starts with **every** heating or cooling call. The HVAC system will run this minimum time even if the temperature reaches setpoint before MRT times out. However, if the mode is set to Off, the MRT will be canceled and the system will

turn off immediately. The default MRT is set to 6 minutes but can be adjusted by the network system variable command from 1 to 9 minutes.

Minimum Off Time (MOT). The HVAC control unit has a minimum off time after **every** heating or cooling call is completed. This off time is used for **short cycle protection** to prevent compressor damage after cooling calls (and heat calls for Heat Pumps). In addition, the MOT helps both Standard and HP systems to prevent rapid cycling of the system, caused by quick temperature changes. The default MOT time is set to 6 minutes but can be adjusted by the system variable network command from 5 to 9 minutes.

The Status LED on the Control Unit circuit board will flash twice during MOT/MRT periods.

Standard HVAC System Setup

Standard System Mode Selection. To set the Control Unit for standard GAS/ELECTRIC operation, set the dipswitch SW1 position 1 to the STD SYS position (SW1-1 = OFF).

Fan Mode Selection. Normally, GAS heating systems DO NOT require fan calls along with the heat call due to automatic fan operation in the furnace. For Gas systems, dipswitch SW1 position 2 should be set to the OFF position (SW1-2 = OFF).

Electric heating systems generally DO require that a fan call be generated along with the heat call. For these systems, dipswitch SW1 position 2 should be set to the ON position (SW1-2 = ON). Be sure to check your HVAC system's requirements.

TU16 Control Unit HVAC System Outputs for Standard Systems

Operating Mode	Outputs (no Fan with Heat)	Outputs (Fan with Heat)
Manual Fan	G	G
Cooling Stage 1	G, Y1	G, Y1
Cooling Stage 2	G, Y1, Y2	G, Y1, Y2
Heating Stage 1	W1	G, W1,
Heating Stage 2	W1, W2	G, W1, W2

HEAT PUMP HVAC SYSTEM OPERATION

The TU16 has Heat Pump operating modes of Heating, Cooling, Auto changeover and Emergency Heat.

The Heat Pump HVAC system operation is the same as for Standard systems for normal first and second stage operations. In addition, Heat Pumps may have a third stage of heating, which is for Auxiliary Heat (such as heat strips). The third stage comes at 5 degrees (default) from setpoint and stays on until temperature drops to 3 degrees from setpoint.

Emergency Heat Mode. When the Control Unit HVAC System Type is selected as a Heat Pump system, an additional operating mode of "Emergency Heat" (EH) can be selected from the WDU mode menu. In the event of a compressor failure, the "EH" mode can be selected. When in this mode, the stage 3 auxiliary heat (heat strips) output (W1) will be ON in lieu of stage 1 heat calls. Compressor stages 1 (Y1) and 2 (Y2) outputs are inhibited to protect from further equipment damage. This mode is for temporary use until the compressor can be repaired.

The EH mode can also be used during extreme low outdoor temperatures when compressor heating is inadequate and Auxiliary Heat is required for heating operation.

Minimum Run Time (MRT). Heat Pump systems have the same MRT delays as Standard systems.

Minimum Off Time (MOT). Heat Pump systems have the same MOT delays as Standard systems.

Heat Pump HVAC System Setup

Heat Pump Type Selection. For Heat Pump systems, set the HVAC system type, SW1 position 1 to the ON position (SW1-1 = ON).

Change Over Selection. Heat Pump systems change from heating to cooling by reversing the direction of refrigerant flow in the system. The change from Heating to Cooling is controlled by the CHANGEOVER (CO) output from the Control Unit (also referred to as the “reversing valve” output). These are the O and/or B terminals on Heat Pump thermostat connections. Always use the O terminal input on the Heat Pump system and select the CO type on the controller as required.

Changeover with Cooling. This is typical of most heat pump systems, which are designed to work normally in the heating mode and require a changeover output for cooling. To select this CO type, set dipswitch SW1 position 3 to the OFF position (SW1-3 = OFF). This is the default setting.

Changeover with Heating. If your system requires changeover with heating, set SW1 position 3 to ON position (SW1-3 = ON).

Changeover Relay Operation: The changeover relay output stays ON after a heating/cooling call for the duration of the MOT minimum off delay period. If another call occurs before the delay period expires, the CO relay will already be on and this avoids continuous on/off cycling the CO valve for each call. After the MOT period expires and another call is not active, the CO output will go OFF.

TU16 Control Unit HVAC System Outputs for Heat Pump Systems

Operating Mode	Changeover with Cool	Changeover with Heat
Manual Fan	G	G
Cooling Stage 1	G, O, Y1	G, Y1,
Cooling Stage 2	G, O, Y1, Y2	G, Y1, Y2,
Heating Stage 1	G, Y1	G, O, Y1,
Heating Stage 2	G, Y1, Y2	G, O, Y1, Y2
Heating Stage 3	G, Y1, Y2, W1	G, O, Y1, Y2, W1
Emergency Heat	G, W1	G, W1

Status LEDs

The Control Unit has a Status LED on the circuit board that will normally blink on and off slowly as a system heartbeat. During short cycle protection delay periods, the LED will blink twice for each heartbeat. This indicates that the compressor is locked out during this time. The other LEDs indicate the operation of the control unit output relays. When the LED's are on, the output relay is on.

LED	Function	Control Unit Output
H1	Heat stage 1 output (Heat stage 3 for HP systems)	W1
Fan	Fan output	G
C1	Compressor stage 1 output	Y1
C2	Compressor stage 2 output	Y2
H2/CO	H2 = Heat stage 2 output for Standard HVAC systems CO = Changeover valve output for Heat Pump HVAC systems.	O (W2) O

Heat Pump changeover (reversing valve) output is dependent on the control unit Dipswitch SW1-3 setting. Change over is either with cool (normal) or with heat.

UPB Communications

UPB – Universal Power Bus. The TU16 Control Unit has a UPB powerline communications port. This port connects to the 120VAC powerline using a UPB powerline interface module (PCS's PIM or Simply Automated's CIM). The TU16 uses standard UPB protocol commands to create a bidirectional thermostat control protocol.

Connecting to the Powerline Network.

The TU16 is provided with an adapter cable to connect the control unit to a UPB powerline interface module (PIM or CIM – not provided). Plug the modular connector end of the cable into the control unit's UPB PLI interface RJ12 jack, J3. The other end of the UPB cable is a DB9 adapter that connects to the UPB PLI module or to a standard serial extension cable connected to the PLI module.

UPB Network Address

UPB network devices have a Network ID, a Unit ID, and a Password.

Default Address Settings:

- Network ID: 255
- Unit ID: 249
- Password: 1234

UPB Network and Unit ID

The UPB Network and Unit ID's can be set from the TU16 Wall Display Unit or by the UPB **UPstart** program or by the control systems software. Check with the manufacturer of the control system for information on setting the UPB device address.

Setting the UPB address directly on the Wall Display Unit

Unit ID: To set the Unit ID address from the WDU, enter the thermostat setup mode by pressing and holding the Mode button and simultaneously press the Fan button. "Ad" will be displayed. Set the **Unit ID** address by pressing the UP/DOWN buttons until the desired address, 1 to 250, is selected.

Note: Addresses from 1 to 99 are directly displayed on the WDU's 2 digit display. Addresses from 100 to 199 are display as 0.0 to 9.9 with the center decimal point on. Address from 200 to 250 are displayed as .00 to .50 with the left decimal on.

Network ID: To set the Network ID, first place the thermostat into **UPB Setup Mode** by simultaneously pressing the MODE and UP buttons. The display will start to flash. Now enter the thermostat setup mode by pressing the MODE and FAN button. "Ad" will be displayed again. This time the address displayed is the UPB Network ID. Set the **Network ID** address by pressing the UP/DOWN buttons until the desired address, 1 to 250, is selected.

UPB Setup Mode

The TU16 can be placed in **UPB Setup Mode** that allows UPB network tools to discover devices on the network and communicate to them without knowing their address. **UPstart** and other control system software may require the thermostat be in "Setup Mode" to use them.

To enter UPB Setup Mode

Press and hold the Mode button and then press the UP button (top button) on the TU16 WDU. The thermostat will indicate that it is in setup mode by flashing the left decimal point display. The control unit LED will be flashing rapidly also. The unit will stay in setup mode for 5 minutes or until you exit setup mode by (1) pressing the MODE/UP buttons again or (2) sending new data from the network tool.

The thermostat can now be discovered on the UPB network using network tools such as the "**UPstart**" program.

You can configure the device Network and Unit ID addresses and Password as desired, and then download them into the control unit. Download UPStart from www.pcslighting.com.

Thermostat Network Control

The TU16 thermostat uses the UPB communications protocol, with extensions, to send and receive network messages. For the complete UPB thermostat protocol, please refer to the RCS UPB Thermostat Protocol Manual, document number 150-00205.

The TU16 has two UPB operation Modes, Link and Message. Link mode is a simple table of UPB Link addresses mapped to thermostat modes or setpoints. Message Mode is a more robust protocol of commands and messages designed for thermostats.

Link Mode Operation

UPB supports 250 Links with IDs from 1 to 250. The thermostat can use link commands to set modes and setpoints. The Link Mode uses 16 consecutive Link ID's which start at the **Base Link ID address**.

For example, the default base address is 200 and the Link ID commands are from 200 to 215.

Link Mode thermostat command table:

Base Address offset	ACTIVATE	DEACTIVATE	Default Link IDs
0	Heat Mode	Off Mode	200
1	Cool Mode	Auto Mode	201
2	Set 40F, 6C	Set 50F, 7C	202
3	Set 60F, 8C	Set 61F, 9C	203
4	Set 62F, 10C	Set 63F, 11C	204
5	Set 64F, 12C	Set 65F, 13C	205
6	Set 66F, 14C	Set 67F, 15C	206
7	Set 68F, 16C	Set 69F, 17C	207
8	Set 70F, 18C	Set 71F, 19C	208
9	Set 72F, 20C	Set 73F, 21C	209
10	Set 74F, 22C	Set 75F, 23C	210
11	Set 76F, 24C	Set 77F, 25C	211
12	Set 78F, 26C	Set 79F, 27C	212
13	Set 80F, 28C	Set 81F, 29C	213
14	Set 82F, 30C	Set 83F, 31C	214
15	Set 84F, 32C	Set 85F, 33C	215

Changing Link Mode Base Address

You can change the Link Mode Base Address over the range of 1 to 235. Use the "Set Variable" command to change the Link Base ID. (Network variable 2)

Inhibit Link Mode Operation

Link Mode operation can be inhibited by a network command. Use the "Set Variable" command to change the Link Mode operation. (Network variable 8)

Message Mode Operation

The following thermostat commands and data are typical of what can be sent and received via the UPB Message Mode communications protocol.

UPB Setup

- Network ID, Unit ID, and Link Mode Base Address
- Password
- Network, Room and Device Names

Thermostat Data and Control

- Request temperature
- Request Heat Setpoint
- Request Cool Setpoint
- Request System Mode (Off, Heat, Cool, Auto)
- Request Fan Mode (Manual Fan Auto/Off)
- Request System Operating State (Off, Heating, Cooling, Fan On/Off)
- Request System Relay State (individual relay output states)
- Set Heat Setpoint
- Set Cool Setpoint
- Set System Mode (Off, Heat, Cool and Auto)
- Set Fan Mode (Auto (manual Off), On (manual On))
- Set Setback Mode

Thermostat Setup

- C/F degree mode
- Minimum Run Time
- Minimum Off Time
- Autosend Mode
- Test Mode
- Inhibit Link Mode
- Display Lockout



Before proceeding with removing an existing thermostat and installing the TU16, Read the following important steps.

1. Record existing wiring information on the enclosed wiring form.
2. Perform the TU16 bench test
3. Check WDU wiring **BEFORE** applying power to control unit.
4. Be sure to install a freeze protection device as required.

Installation Overview

Standard thermostat wiring vs TU16 in retrofit applications.

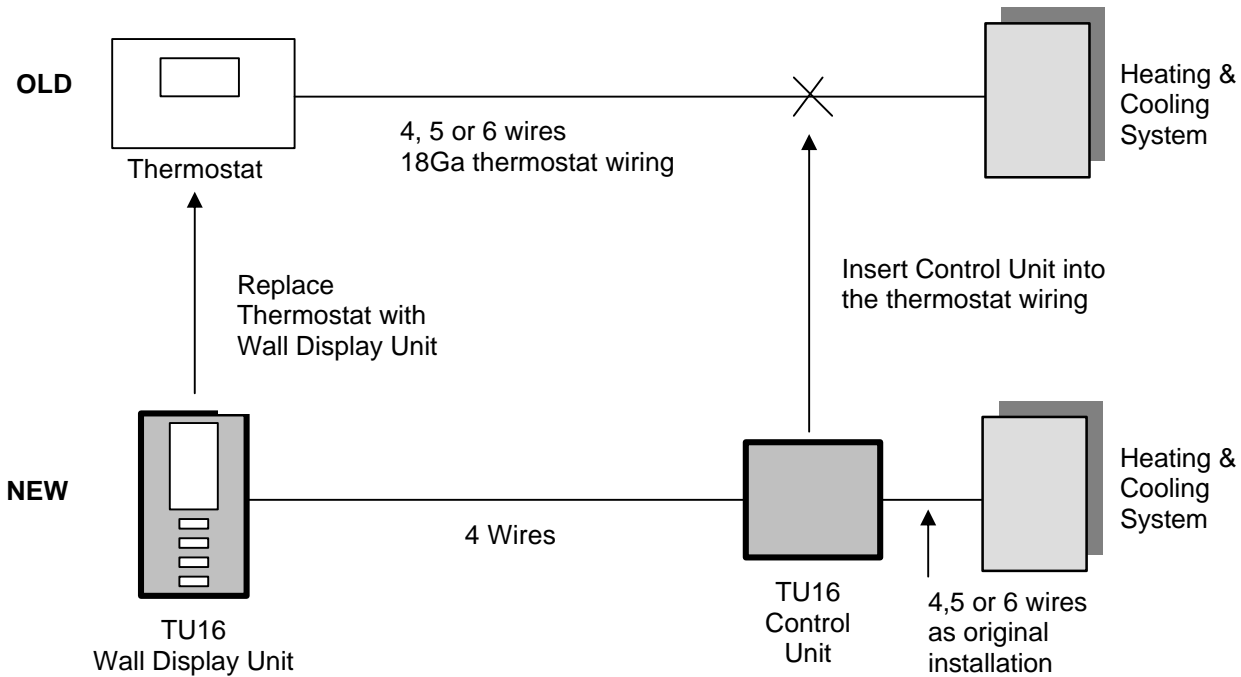

Freeze Protection.

In cold climates that require the heating system to be used for building freeze protection, a mechanical backup freeze protection device **MUST** be installed on the heating system. This can be a simple mechanical heating thermostat or a preset thermostat installed in the heated area.

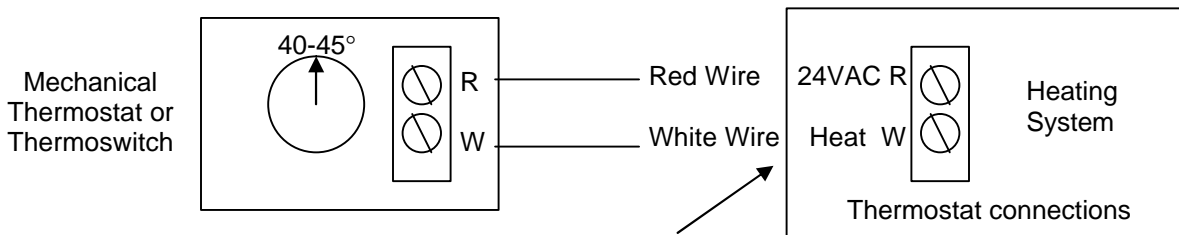

TU16 Wall Display Unit Installation

WDU Location Choose a location that best represents the temperature of the area to be controlled. Avoid locations that are subject to drafts, from doors and windows, or areas with direct sunlight exposure.

WDU Mounting Route the wires to the WDU through the access hole in the back of the case. Mount the WDU to the wall with the screws and anchors provided. Be sure to plug any large access hole in the wall with sealer or insulation to prevent wall drafts from affecting WDU operation.

WDU Prewiring The recommended wiring to the WDU from the Control Unit should be a two twisted pair cable, 24 Ga minimum. Cat 3 or 5, 4 pair cabling is acceptable. In retrofit applications the existing thermostat wiring (a least 4 wires) may be adequate. However, such non-twisted wiring may be subject to interference due to noise from adjacent wiring or other sources.

Wiring to the Wall Display Unit

OPENING AND CLOSING THE WDU CASE

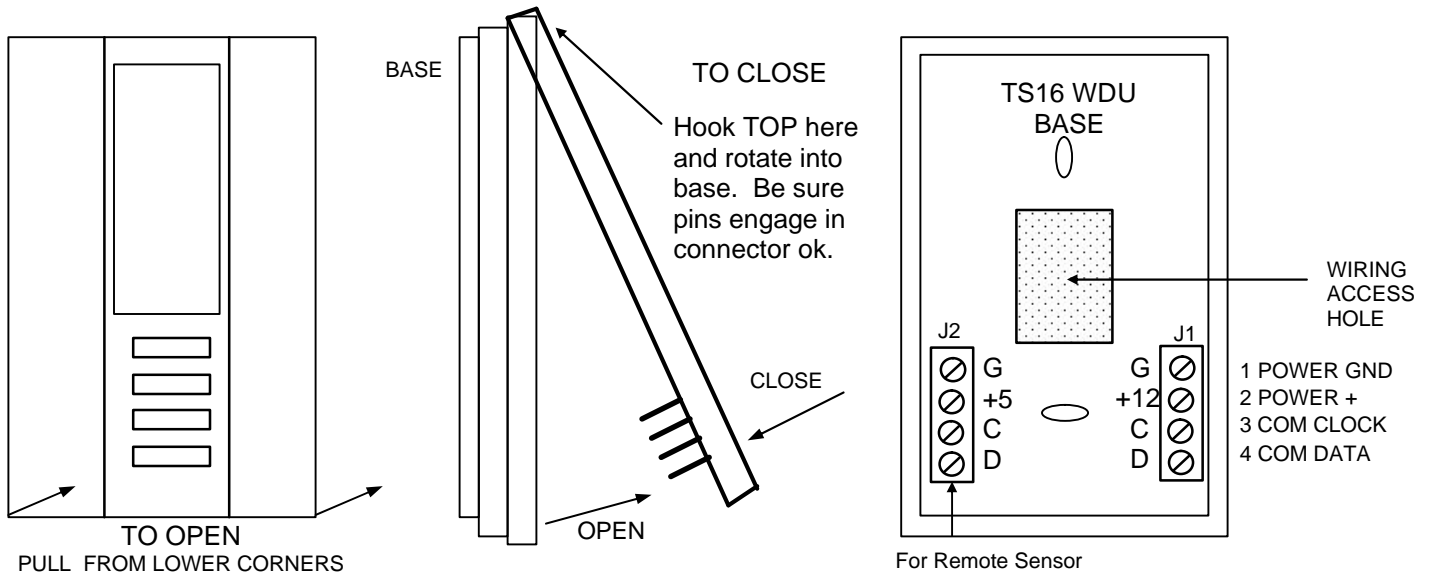

WDU WIRING DIAGRAM

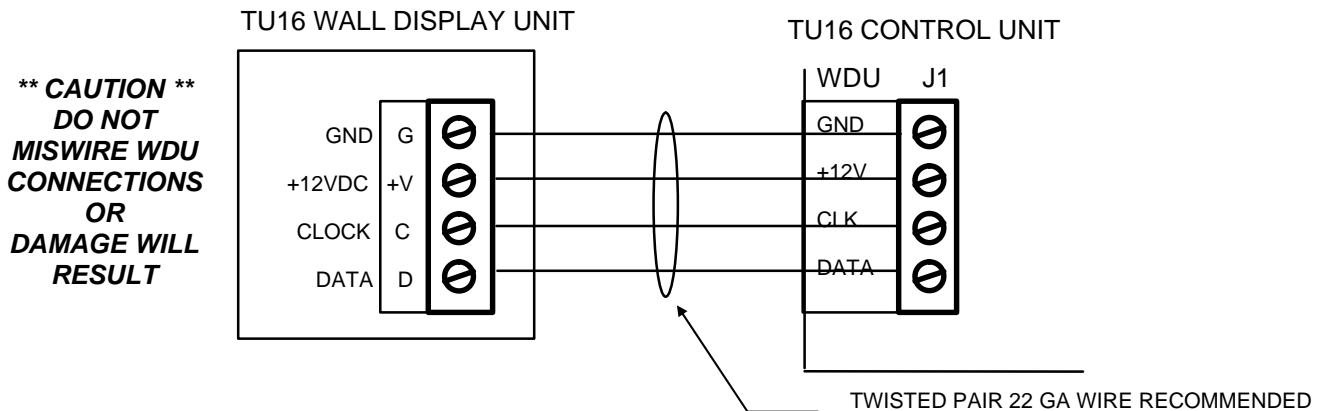

Remote Sensor Wiring

The TS16 WDU has an addition connector, J2, on the WDU base for connection of an external remote temperature sensor. Follow the wiring diagram with the remote sensor to connect to the WDU.

TU16 Control Unit Installation

Location and Mounting

Install the TU16 Control Unit in a protected, convenient, INDOOR location near the HVAC system or in a service accessible area such as an equipment closet or garage.

Mount the Control Unit in a vertical position on a wall or sturdy structural member. The unit may be mounted on the HVAC system but care should be taken to avoid the hot burner section or high vibration fan areas. The unit requires connection to 120VAC for the UPB powerline interface module, so it must be close to a 120VAC outlet.

Control unit wiring

The TU16 HVAC Control Unit is connected to the HVAC system, the Wall Display Unit, and the 120VAC powerline via the UPB powerline module.

Control Unit to WDU wiring

Connect the WDU to the Control Unit with existing thermostat wiring in retrofit installations. For new installs, 22/24 GA twisted pair, typically Cat 3 or Cat 5 wiring is preferred.

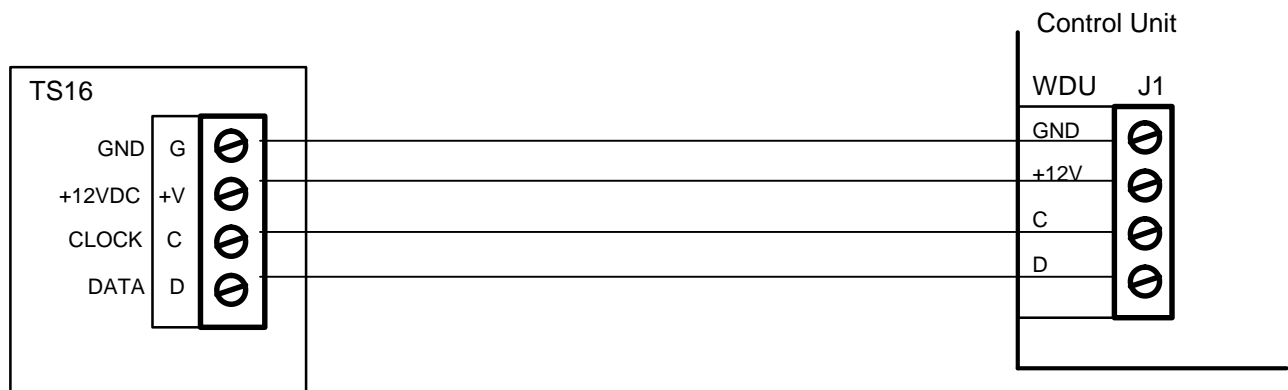

Control Unit to HVAC System Wiring

Electrically, the Control Unit looks like a standard thermostat to your HVAC system. All connections to the HVAC system are made at the normal thermostat connections on the HVAC unit.

You are advised to refer to your HVAC system's documentation for specific information on its thermostat connections and setup requirements. You must know the following:

1. HVAC system type: Gas, Electric, or Heat Pump
2. Fan type: No fan with Heat (typical of Gas systems) or Fan with Heat (typical of Electric heat systems)
3. For Heat Pump systems: Changeover with cool or with heat. (O or B connection)

Note on retrofit wiring. You may note (and be sure to note on the wiring form) that you have additional wires when you disconnect your old thermostat. Usually these wires are for auxiliary functions such as filter or trouble indicators. For Heat Pump systems there may be emergency heat (EH) wiring or both O and B changeover connections. These wires are not used in the TU16 installation and, in most cases, these extra wires are not required for normal HVAC system operation.

Refer to the following HVAC wiring diagrams for your type of HVAC system, Standard or Heat Pump.

HVAC System Wiring - Standard Gas/Electric

Diagram 1 - Standard Gas or Electric System Wiring

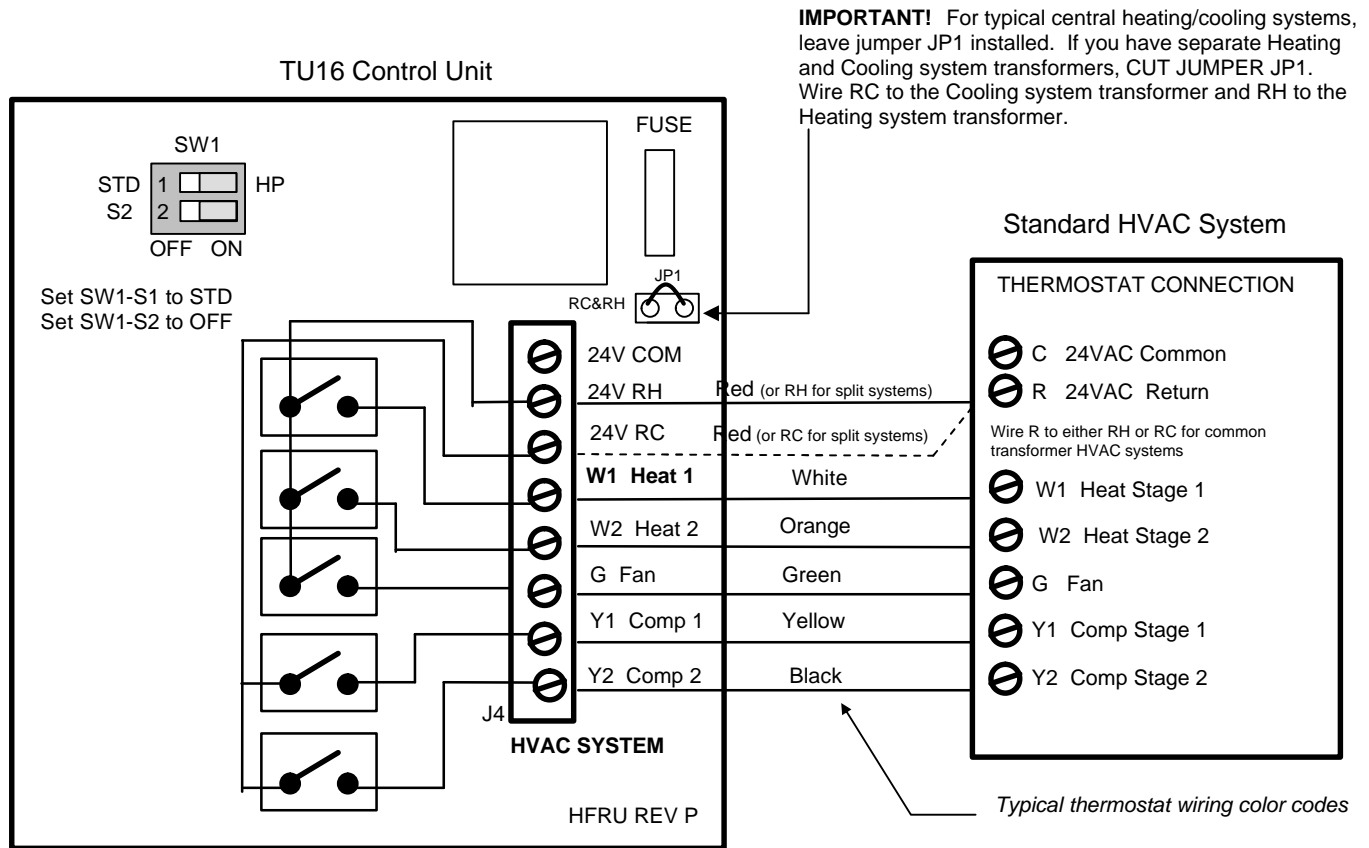

Standard HVAC System Setup Notes:

Single Stage Systems use W1 for heating stage 1, and Y1 for cooling stage 1.

Two Stage Heating systems use W1 for stage 1 and W2 for stage 2 heating.

Two Stage Cooling systems use Y1 for stage 1 and Y2 for stage 2 cooling.

HVAC System 24VAC Transformer

If you have an integrated heating and cooling system with a single transformer, **do NOT cut jumper JP1**. Wire the 24V Return (red) wire to either RH or RC. This is typical of most central systems.

*If you have separate heating and cooling systems with separate transformers, **cut jumper JP1**. Wire the heating 24V R (red) wire to the control unit's RH terminal and run the cooling systems 24V R (red) wire to control unit's RC terminal. Also wire the cooling systems 24VAC Com to the control units 24VAC Com terminal.*

Dipswitch SW1 Setup for Standard HVAC Systems

1. Set SW1-1 (position 1) to the STD position. (Off - to the left) (default setting)
2. Set SW1-2 (position 2) to the correct setting for your HVAC system.
 - a. **Gas furnaces** do not require fan outputs for heating calls. Set SW1-2 to the Off - to the left. (default)
 - b. **Electric furnaces** do require fan outputs for heating calls. Set SW1-2 to the On - to the right.

HVAC System Wiring - Heat Pump Systems

Diagram 2 - Heat Pump System Wiring

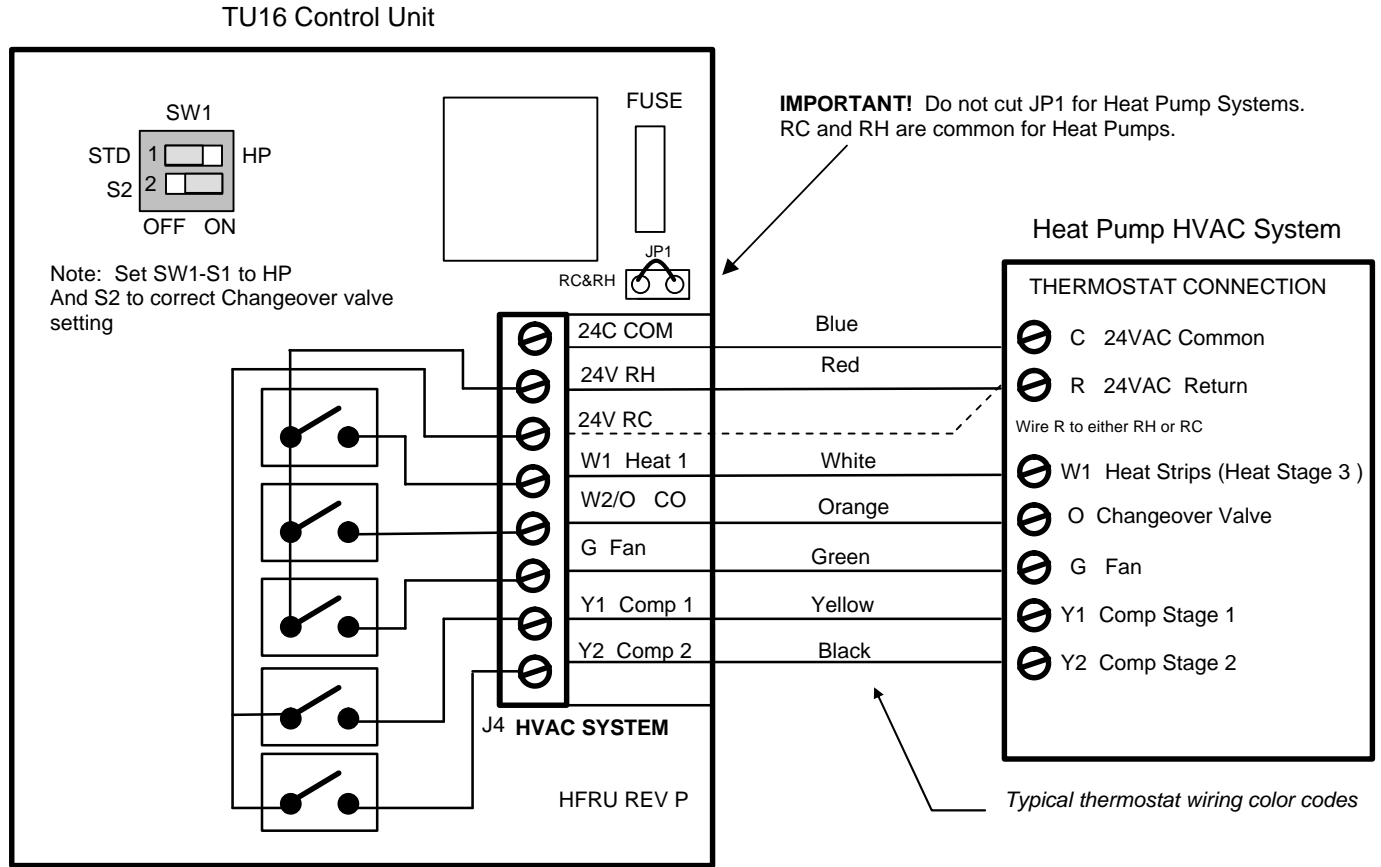

Heat Pump HVAC System Setup Notes:

Single Stage Compressor Systems use **Y1 for stage 1** heating/cooling, and **W1 for stage 2** heating (heat strips).

Two Stage Compressor Systems use **Y1 for stage 1**, **Y2 for stage 2** heating/cooling, and **W1 for stage 3** heating (heat strips).

NOTE: You must configure the Changeover valve setting to work correctly with your HVAC system. Set Dipswitch SW1 as below for correct changeover operation. Changeover with cool is typical for most systems. Check your system information to be sure. If you get cooling when you expect heating, change SW1-S2 to the other position.

Dipswitch SW1 Setup for Heat Pump HVAC Systems.

1. Set SW1-1 (position 1) to the Heat Pump position. (On - to the right)
2. Set SW1-2 (position 2) to the correct changeover (reversing valve) setting for your Heat Pump system.
 - a. For systems with changeover with cooling, Set SW1-2 to Off - to the left (default setting)
 - b. For systems with changeover with heating, Set SW1-2 to On - to the right

TU16 Power Connection

Power from the HVAC System

The TU16 Control Unit connects to the HVAC system's thermostat connections and receives 24VAC power from it.

All most all HVAC systems have standard thermostat connections. This may be a thermostat terminal strip on the system control board or color coded wires. Typically, these connections are marked as follows:

Terminal Marking	Wire Color	Use
C	BLUE	24VAC Common power
R	RED	24VAC Return power
G	GREEN	Fan signal
W	WHITE	Heat signal
Y	YELLOW	Cool signal

There may be others like orange, brown and black for other functions, refer to the HVAC wiring diagrams.

**You must connect both power connections to the TU16 control unit:
the 24VAC common, typically marked as C on the thermostat connections or the BLUE wire,
and
the 24VAC return, marked R on the thermostat connection or the RED wire.**

Note: If the HVAC system power is off, then power to the thermostat will be off as well.

HVAC System Transformer Types

Most Common Type: By far the most common HVAC system is the Standard Gas central heating/cooling forced air system with a single 24VAC power transformer. (Electric heating also falls into this category)

Separate Heating and Cooling systems: These are essentially two systems with a common air handler or blower. In this case there is a separate heating 24VAC transformer and a cooling 24VAC transformer. This type of a system requires that the TU16 Control Unit be connected using a separate heating system power input R terminal (RH) and a separate cooling system power input R terminal (RC). When connecting to these systems you must "split" the RH/RC power connections on the TU16 HVAC control unit HVAC terminal connections (J4). See wiring diagram for instructions on cutting this jumper, JP1.

Heat Pump Systems: These systems have a common transformer like standard central heat/cool systems. Wire the HVAC system R to either of the TU16 Control Unit's RH or RC terminals.

Connecting the HVAC system power to the TU16 HVAC Control Unit

For all systems:

Connect the HVAC system 24VAC Common C (or Blue wire) to J4 24Com connection.

For Standard and Heat Pump systems:

Connect the HVAC system 24VAC Return R (red wire) to either the control units J4 RH or RC terminals (they are jumpered together by JP1)

For "split" or separate heating /cooling transformers systems:

First CUT the jumper wire at JP1 (this separates the RH and RC terminals)

Connect the heating system's R terminal (or red wire) to the control units J4 RH terminal.

Connect the cooling system's R terminal (or red wire) to the control units J4 RC terminal.

It is strongly recommended that you hook-up and run a simple bench test before installing the TU16. Not only will this save you time in system checkout but will also familiarize you with the thermostat's operation.

THERMOSTAT BENCH TEST

1. Connect the Wall Display Unit to the Control Unit with a short (12-24 inch) 4 wire cable.
2. Before power up, set the Control Unit dipswitch, SW1, to ALL OFF
3. Connect power to the Control Unit. **You will need a separate 24VAC transformer if you are not connected to the HVAC system thermostat connections for power.**
4. Verify Control Unit Status LED is blinking.
5. Verify the WDU display comes on and shows the current temperature.
 - a. If no display and backlights are not on, check wiring and power at the Control Unit.
 - b. If a "CF" display is shown on the WDU, double check your wiring to the Control Unit.
 - d. Do not proceed until the current temperature is displayed on the WDU.
6. With the current temperature displayed on the WDU, we have verified communication between it and the Control Unit is OK. Any communication problems will result in a "CF" (Communications Failure) display on the WDU and must be fixed before proceeding. If all is OK with the WDU proceed to the next step.
7. Press the Fan button on the WDU. The Control Unit's Fan LED and relay should turn on.
8. Press the Fan button again. The Fan LED and relay should turn off.
9. Press the Mode button until the WDU is showing "H" for Heat Mode.
10. Press the Setpoint Up button until the setpoint is above the current temperature. The Heat LED and relay should come on. (If they don't, make sure the Status LED is not flashing twice indicating minimum off delay...wait until LED stops flashing twice before proceeding).
11. Press the Mode button until the WDU is showing "O" for OFF. The Heat LED and relay will turn OFF.
12. Wait 6 minutes for the minimum off delay to expire. The Status LED will stop flashing twice.
13. Press the Mode button until the WDU is showing "C" for Cool Mode.
14. Press the Setpoint Down button until the setpoint is below the current temperature.
15. The Compressor and Fan LEDs and relays should turn on.
16. Press the mode button until the WDU is showing "O" for OFF Mode.
17. All LEDs and relays should turn off.
18. When you have successfully completed all these tests, you have verified that the TU16 is working correctly.

HVAC System Testing

If you need to verify that the HVAC system is operational, you can perform the following test.

Thermostats, like the TU16, are just switches to the HVAC system as shown in the diagram below. This is a simplified example of a thermostat and a standard HVAC wiring diagram. The HVAC system operation can be tested by duplicating the thermostat switch operation by shorting across the thermostat terminals on the HVAC system.

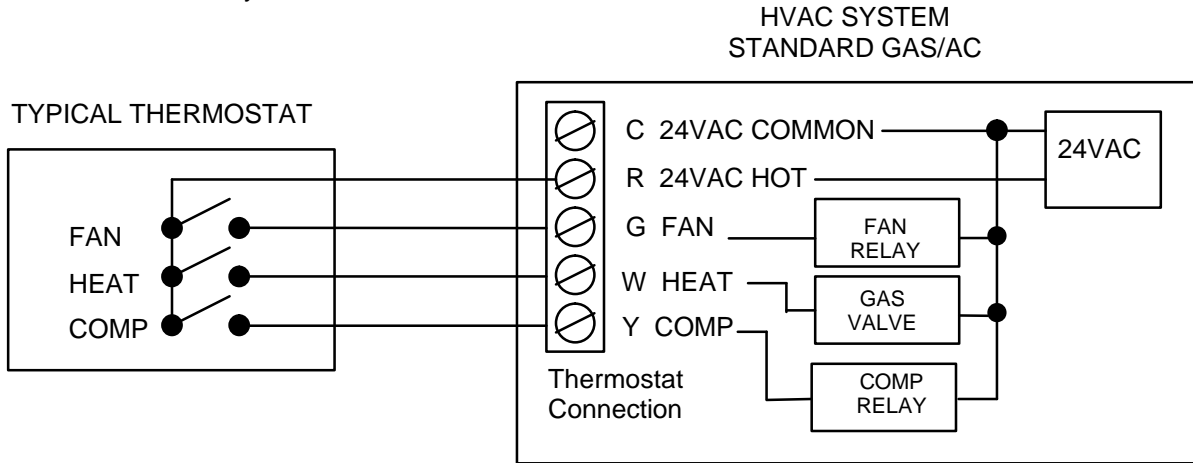

Note: The HVAC system and thermostat connection voltage is 24VAC. This is a safe voltage to work with but be careful to avoid shorting the 24VAC common (C) and 24VAC return (R) terminals. This may blow a fuse in the HVAC system.

Standard HVAC System Quick Test

You can perform a quick test of the HVAC system by shorting across the appropriate thermostat terminals on the HVAC thermostat connector. Use a short 6 inch wire to connect across the following terminals.

Function Test	HVAC Terminals	Result
Fan	R to G	Fan should come on
Heating	R to W	Heat cycle should start for heating
Cooling	R to Y and G	Compressor and Fan should start for cooling

Heat Pump System Quick Test

Similarly, you can test Heat Pump operation by shorting across the following terminals. Heat pump operation is determined by compressor calls in conjunction with changeover (O) outputs. You must know what your system CO type is (CO with Cool (typical) or CO with Heat). You should have configured the TU16 control unit for correct CO type, refer to this setting. Heat Pump systems have an additional O terminal.

Function Test	HVAC Terminals	Result
Fan	R to G	Fan should come on
Heating	R to Y and G	Compressor and Fan should start and Heating occurs.
Cooling	R to Y and G and O	Compressor and Fan should start. CO valve operates and Cooling occurs.

Note: if you have the CO selection incorrect you will get cooling when you expect heating and vice versa. Change the dipswitch SW1-3 changeover setting to correct this problem.

TU16 CONTROL UNIT

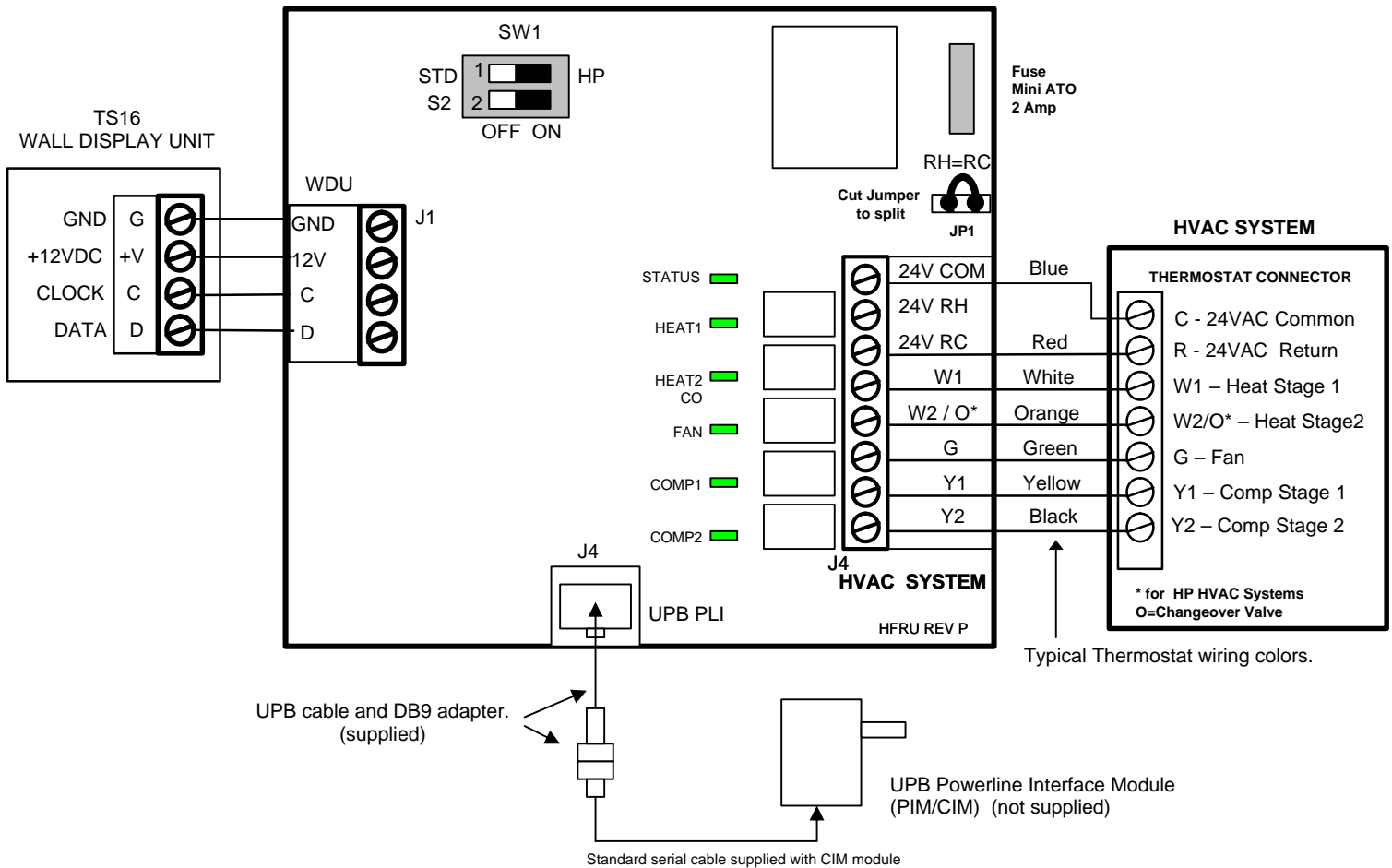

HVAC System Transformer

Most central HVAC systems have a common heating and cooling transformer. This is the factory default setting for Jumper JP1. In some cases, you may have separate heating and cooling systems, each with their own transformer. In that case, cut Jumper JP1 and wire the heating transformer red wire to the RH terminal and the cooling system transformer red wire to the RC terminal. Wire the cooling system's 24VAC Com to the control unit's 24VAC Com terminal.

Dipswitch SW1 Settings: (White is switch position)

SW1-S1, STANDARD OR HEAT PUMP SYSTEM SELECTION

HVAC Systems can be either Standard Gas/Electric systems or Heat Pump systems.
 Set S1 to STD SYS (OFF) for Gas/Electric systems (default setting).
 Set S1 to ON for Heat Pump systems

SW1-S2 Fan Type or HP Changeover Valve Selection

If S1 is set to Off for Standard HVAC systems, then S2 selects the HVAC **fan type**.
 Set S2 to OFF for gas systems that do not require Fan w/heat calls.(default setting)
 Set S2 to ON for electric systems.

If S1 is set to On for HP HVAC systems, then S2 selects the **changeover or reversing valve type**.

Set S2 to OFF for changeover with cooling (default setting).
 Set S2 to ON for changeover with heating