

RCS

Model 8R5PR

8 Channel
RS485 Relay Controller

A CommStar RS485 Network Device

Installation Manual

For Product Revision
001-01407 Rev 04
or later

DCN: 140-01407-02
6/04/07

Model 8R5PR Installation Manual

Features

- 8 Channel Relay Controller
- 5 Amp Relays
- RS485 Network Interface (addresses 1 to 16)
- Programmable Individual Relay Channel Operation
 - Latched mode
 - Pulsed mode (with programmable pulse length up to 3240 seconds (54min))
- For use on CommStar Control Units RS485 Channels
- Supported by **WinEVM** PC Setup and Programming Software (16 controllers)

Product Contents

This product kit contains the following items:

- 1 8R5PR Control Unit
- 1 Power Transformer, 120VAC/12VDC, 500mA
- 1 Installation Manual

Relay Channel Specifications

Channels: 8
Type: SPDT
Contact Rating: 5A 30VDC/ 5A 240VAC

WARNING! This unit is not rated for use with 120/240Volt connections.

Relay LEDs

Each relay channel has an indicator LED. The LED will be on when the relay is on.

Status LED

The Status LED is a multifunction indicator that shows that the power is on and the unit is working properly. It also acts as an RS485 signal reception indication by flashing when RS485 commands **are received AND are addressed to the unit**.

LED flashing slowly: When the control unit is first powered up, the status LED will start flashing slowly to indicate that power is OK and the unit is running. Slow flashing also indicates that no RS485 commands are being received that are addressed to this unit.

LED flashes rapidly: When an RS485 network command is received by the unit and it is addressed to the unit, the status LED will flash rapidly. Once the network recognizes the unit and starts polling the unit frequently, the LED may flash rapidly continuously (depends on how many devices are on the network).

Auxiliary Power Output

The 8R5PR has auxiliary 12VDC power output terminals (J13) that can be used to provide power to switched loads. Max power output available for all loads is 400mA. This output is protected by a resettable fuse on the 8R5PR control board. Fuse will reset 30-90 seconds after short removed.

Installation

It is recommended that you Bench Test the unit before installation!

Refer to the wiring diagram at the end of this document.

Connect the 12VDC power transformer provided to the 8R5PR 's power jack. Plug in the power transformer to an 110VAC outlet.

Note: for continuous operation of the unit, be sure the outlet is not switched.

Do NOT connect the network connection yet.

The Status LED should be flashing slowly. This indicates that the unit has powered up OK and it is ready. Do NOT proceed until you get the slow flashing LED state.

Set the units RS485 network address on dipswitch SW2. See the dipswitch address setting section.

Connect the 8R5PR control unit RS485 terminals to a RS485 channel on the CommStar Controller or the external RS485 Star Hub, if used.

- Follow the wiring diagrams in this document.
- Be sure to connect the RS485 communications terminals D+ to D+ and D- to D-.
- NOTE: The CommStar RS485 channel's 12V connection is not used.

Configure the CommStar Control Unit to add the device to its RS485 network using the WINEVM software. Use the "Define" menu item and Select "RS485 I/O devices" (or 8CUR on older versions).

Refer to the **8R5PR Setup** section and the WinEVM manual for complete setup and programming instructions.

Once the CommStar Control Unit recognizes the 8R5PR device and starts polling it, the Status LED will start flashing rapidly.

You are ready to use the unit!

Connecting Loads to the Relays.

Each relay channel has a Normally Open (NO) and a Normally Closed (NC) contact as well as the Common (C) connection. Connect your loads as desired.

Do NOT exceed the relays 5 Amp rating.
Do NOT exceed the 40V Class 2 Voltage rating.
Do NOT use with 120VAC or 240VAC loads.

Connecting Inductive Loads

If you are controlling inductive loads like large contactors/relays, solenoids or sprinkler valves, you must install transient voltage suppressor/surge absorbers (called "ZNR" devices) across the relay contact terminals (The Com and NO terminals typically) to provide arc suppression and noise reduction.

For 24VAC loads (a sprinkler valve for example), use a 56 volt ZNR. Reference Part: Panasonic part number: ERZ-V07D560, available from Digi-Key, Part Number: P7296-ND (www.digikey.com)

A kit of 8 ZNR's is included with the control unit. Additional ZNR's are available from Digi-Key.

See Wiring Diagram for connection information.

RS485 Operation

The 8R5PR relay control board is controlled by network commands from the RCS CommStar RS485 network. It is a half duplex, 2 wire (with ground) network. Data signals are Data + and Data -.

The network protocol is 9600 baud, no parity, 8 data bits, 1 stop bit and no flow control.

The 8R5PR is designed for use with RCS CommStar Control Units. Use the WinEVM PC setup and programming software provided with the CommStar Control Units to configure and use this product.

RS485 Network Connection

Connect the RS485 network Ground, Data + and Data - wires to the J9 RS485 terminal block. Watch network polarity. Always wire + to + and - to -. If you cannot communicate, try reversing the + and - connection.

Recommended wiring is Cat 3 or Cat 5 cable. Max cable length is 4000 ft but actual max depends on network wiring topology (multi-drop or star) and network hubs, if any.

Recommended wiring topology is RCS CommStar RS485 Star Hubs (CS308 built-in hub or 8AH485 external hubs). Each network device is homerun wired to its own channel on a hub. Allows 4000 ft max cable length.

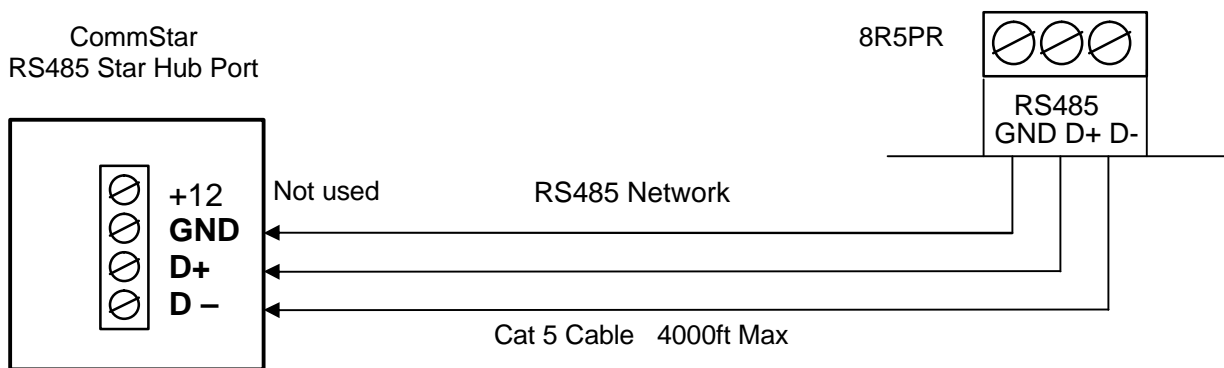

Setting the Network Address (New! this version now supports 16 addresses)

The 8R5PR network address is set with the 4 position dipswitch, SW2. Set the dipswitch as follows for the RS485 network address. Be sure all connected 8R5PR units are set to **a different** network address.

RS485 Address Dipswitch Settings (default set to address 1). The address in hex is shown in the boxes.

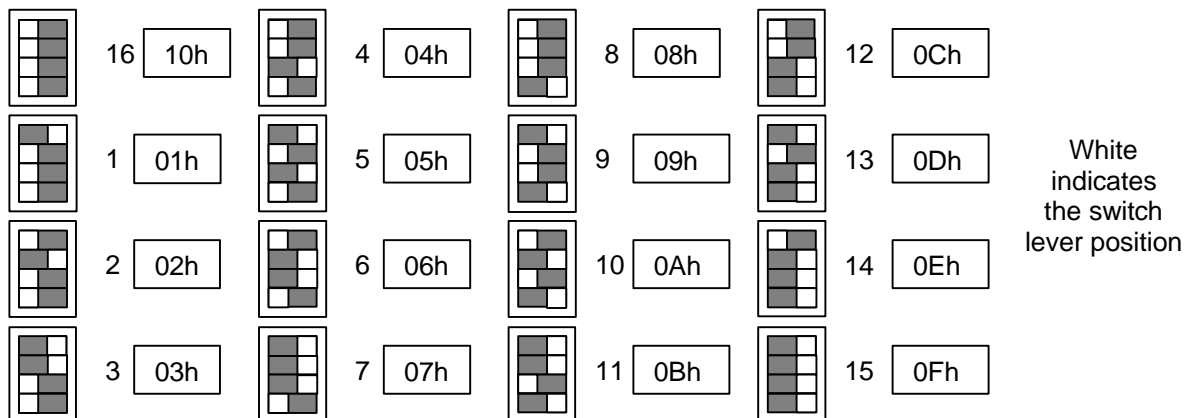

8R5PR Setup

The 8R5PR needs to be “defined” to the CommStar Controller it is connected to. The WinEVM PC setup program provided with the control unit is used for this purpose.

Install WinEVM on your PC and connect the CommStar Controller to the PC serial port. Start the program and verify you are correctly connected to the control unit. Use “Sys Info” to check your connection.

Define the device to the system:

- Select the “Define” menu item in the WinEVM main menu bar.
- Select “RS485 I/O” from the Define drop down menu.
- Select the device with the address you want to install. (ex: “Addr1:”)
- Click on “Define”.
- A Window will pop-up for that device address. (ex: “RS485 Address 1”)
- Select the device type “8 Ch Relay”.
- Enter the Name for the device. (this will show up in schedules and logs)
- Enter a Name for each relay channel.
- Click on “OK” to exit.
- The device is now configured.

Testing the 8R5PR

Once defined, you can test the device using the WinEVM’s Mega Controller direct I/O commands. Open the Mega Controller window by clicking on the main menu bar item.

- Select the “I/O” button in the Mega Controller Window.
- The “I/O Access” window will open. It will show the 8R5PR device you have just defined (and any others previously defined).
- Select a relay channel on the 8R5PR.
- Click on “Set Relay” to turn on the relay or “Clear Relay” to turn off the relay.
- Relays will turn On and Off as commanded. The relay state will change with each command.

Check “Relay Outputs” in the **Logging Messages** list. The relay state changes will show up in the Mega Controller’s logging window.

Using the 8R5PR

Once the device is defined to the system, individual relay channels can be used in the following programming functions:

- THEN Actions in Events
- THEN Macros
- IF Macros (the relay state)
- KPG8 LCD Keypad button actions

Relay Programming

When adding a “Relay Output” to a WinEVM Schedule Event, you can select the output to be either:

- On/Off
- Pulse output

Pulse output length can be defined as fixed number of seconds (1 to 3240) or as a user defined variable. See the WinEVM programming manual for details on relay output programming.

Wiring Diagram Rev F/G PCB

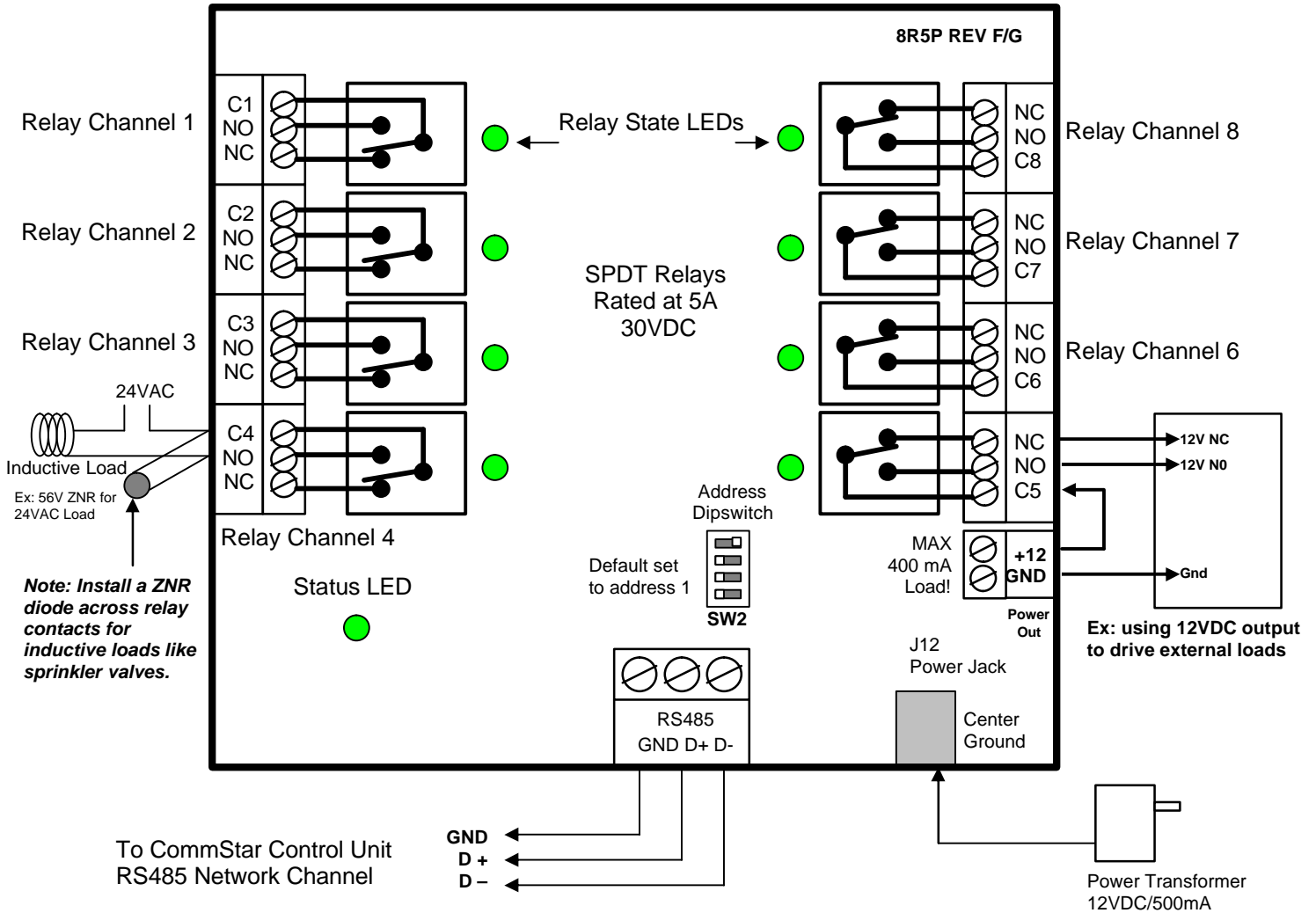

Status LED: Operating Mode	Function
Slow flashing	Power on, unit ready, but no RS485 commands being received
Fast flashing	RS485 network command received and for this unit's address.
Note: When connected to a CommStar RS485 network, the LED may flash continuously due to frequent polling.	

INDUCTIVE LOAD NOTE: If you are controlling inductive loads like large contactors/relays, solenoids or sprinkler valves, you must install transient voltage suppressor/surge absorbers (called "ZNR" devices) across the relay contacts to provide arc suppression and noise reduction. For 24VAC Loads (sprinkler valves), use a 56 volt ZNR. 8 are included with the unit. If you need additional ZNRs, they are available from DigiKey (www.digikey.com) Reference Part: Panasonic part number: ERZ-V07D560, DigiKey Part Number: P7296-ND